

Jennifer Tabakin
Town Manager

E-mail: jtabakin@townofgb.org
www.townofgb.org



Town Hall, 334 Main Street
Great Barrington, MA 01230

Telephone: (413) 528-1619 x2
Fax: (413) 528-2290

TOWN OF GREAT BARRINGTON MASSACHUSETTS

OFFICE OF THE TOWN MANAGER

SELECTBOARD'S MEETING

MONDAY, JUNE 23, 2014

7:00 P.M. – REGULAR SESSION

TOWN HALL, 334 MAIN STREET

ORDER OF AGENDA

7:00 PM - OPEN MEETING

1. CALL TO ORDER.

2. APPROVAL OF MINUTES:

May 27, 2014 Regular Meeting
June 2, 2014 Strategic Planning Priorities Meeting
June 17, 2014 Special Meeting

3. SELECTBOARD'S ANNOUNCEMENTS/STATEMENTS:

- A. GENERAL COMMENTS BY THE BOARD.
- B. DISCUSSION OF UPCOMING MEETING CALENDAR.

4. TOWN MANAGER'S REPORT:

- A. FOLLOW UP ITEMS
 - VACANCIES ON TOWN BOARDS/COMMITTEES/COMMISSIONS.

5. PUBLIC HEARING:

- A. HOUSATONIC SOLAR 1, 105 TAMARA CIRCLE, AVON, CT FOR WORK IN THE FLOODPLAIN AT 0 PARK STREET (MAP 7, LOT 30), HOUSATONIC, MA IN ORDER TO CONSTRUCT A SOLAR ARRAY IN ACCORDANCE WITH SECTIONS 9.1 AND 10.4 OF THE GREAT BARRINGTON ZONING BYLAW.
 - a. Open Public Hearing
 - b. Explanation of Project
 - c. Speak in Favor/Opposition
 - d. Motion to Close Public Hearing
 - e. Motion re: Findings
 - f. Motion re: Approval/Denial/Table
- B. CONTINUATION OF THE SPECIAL PERMIT APPLICATION OF ST. JAMES PLACE/FRED AND SALLY HARRIS, 352 MAIN STREET, GREAT BARRINGTON FOR A COMMUNITY CENTER USE IN B-2 ZONE, DEVIATION FROM CERTAIN PARKING REQUIREMENTS, AND EXTERIOR ALTERATIONS IN THE VILLAGE CENTER OVERLAY DISTRICT, IN ACCORDANCE WITH SECTIONS 3.1.4 B (6), 6.1, 9.6 AND 10.4 OF THE GREAT BARRINGTON ZONING BYLAW.

- a. Open Public Hearing
- b. Explanation of Project
- c. Speak in Favor/Opposition
- d. Motion to Close Public Hearing
- e. Motion re: Findings
- f. Motion re: Approval/Denial/Table

6. LICENSES OR PERMITS:

- A. **CONTINUATION**- LYNN A. HUTCHINSON FOR A DRIVEWAY PERMIT AT THE WEST SIDE OF LONG POND ROAD/NORTH SIDE OF ASSESSOR MAP 33, LOT 3. (DISCUSSION/VOTE)
 - B. RICHARD ROTHBARD/AMERICAN ART MARKETING D/B/A BERKSHIRE ARTS FESTIVAL FOR TWO (2) TEMPORARY WEEKDAY ENTERTAINMENT LICENSES FOR JULY 4 AND 5, 2014 FROM 1:00 PM - 3:00 PM AT SKI BUTTERNUT, 380 STATE ROAD. (DISCUSSION/VOTE)
 - C. RICHARD ROTHBARD/AMERICAN ART MARKETING D/B/A BERKSHIRE ARTS FESTIVAL FOR TEMPORARY SUNDAY ENTERTAINMENT LICENSE FOR JULY 6, 2014 FROM 1:00 PM - 3:00 PM AT SKI BUTTERNUT, 380 STATE ROAD. (DISCUSSION/VOTE)
 - D. ILAN BACHRACH/MASS LIVE ARTS FOR SIXTEEN (16) ONE DAY BEER AND WINE LIQUOR LICENSES FROM JULY 7 – JULY 26, 2014 (PER ATTACHED) FROM 6:00 PM-12:00 AM AT DANIEL ARTS CENTER, BARD COLLEGE AT SIMON’S ROCK, 84 ALFORD ROAD. (DISCUSSION/VOTE)
 - E. CATHY INGRAM/BARD COLLEGE AT SIMON’S ROCK FOR ONE DAY BEER AND WINE LIQUOR LICENSE FOR SATURDAY, JULY 12, 2014 FROM 3:00 PM – 9:00 PM AT DINING HALL AND TRI DORM LAWN AT BARD COLLEGE AT SIMON’S ROCK, 84 ALFORD ROAD. (DISCUSSION/VOTE)
 - F. JOHN KROL/THE KINDRED GR8T ROAD RACE FOR PERMISSION TO HOLD AN 8 MILE ROAD RACE ON SATURDAY, AUGUST 16, 2014 STARTING AT 8:00 AM NEAR THE NEWSBOY STATUE ON SILVER STREET AND FINISH NEAR THE KINDRED FACILITY ON MAPLE AVENUE. (DISCUSSION/VOTE)
 - G. VERIZON NEW ENGLAND, INC. FOR PERMISSION TO REPLACE MANHOLE ON THE ON THE WESTERLY SIDE OF MAIN STREET AT THE INTERSECTION OF MAIN STREET AND ELM STREET; REPLACE MANHOLE ON THE WESTERLY SIDE OF MAIN STREET AT THE INTERSECTION OF MAIN STREET AND DRESSER AVENUE AND INSTALL TWO (2) FOUR (4) INCH CONDUITS BETWEEN MANHOLES. (DISCUSSION/VOTE)
- 7. NEW BUSINESS:**
- A. SB/ISSUING AUTHORITY’S CONSENT/RESOLUTION FOR TIME WARNER’S TRANSFER OF CONTROL TO COMCAST CORPORATION (COMCAST). (DISCUSSION/VOTE)
 - B. SB - EXTENSION OF AGREEMENT WITH CET FOR HAZARDOUS HOUSEHOLD WASTE COLLECTION. (DISCUSSION/VOTE)
 - C. SB – PROCLAMATION FOR W.E.B. DU BOIS FAMILY. (DISCUSSION/VOTE)
 - D. FY 15 RE-APPOINTMENTS. (DISCUSSION/VOTE)

8. OLD BUSINESS:

9. CITIZEN SPEAK TIME:

10. SELECTBOARD'S TIME:

11. MEDIA TIME:

12. ADJOURNMENT:

NEXT SELECTBOARD'S REGULAR MEETING: MONDAY, JULY 14, 2014 AT 7:00 P.M.

Jennifer Tabakin, Town Manager

THIS MEETING MAY BE RECORDED BY MEMBERS OF THE MEDIA. THE LISTING OF AGENDA ITEMS ARE THOSE REASONABLY ANTICIPATED BY THE CHAIR WHICH MAY BE DISCUSSED AT THE MEETING. NOT ALL ITEMS LISTED MAY IN FACT BE DISCUSSED AND OTHER ITEMS NOT LISTED MAY ALSO BE BROUGHT UP FOR DISCUSSION TO THE EXTENT PERMITTED BY LAW.

MEETINGS IN JULY

(Scheduled as of 6/19/14)

- Monday, June 23rd at 5 PM Parks Commissioners- Mason Library
- Wednesday, June 25th at 1:30 PM Council on Aging- Claire Teague Senior Center
- Wednesday, June 25th at 6:30 PM Conservation Commission- Town Hall
- Thursday, June 26th at 4 PM Downtown Parking Task Force- Town Hall
- Thursday, June 26th at 7 PM Planning Board- Town Hall
- Tuesday, July 1st at 6 PM Selectboard Special Meeting- Town Hall
- Wednesday, July 2nd at 5:15 PM Tree Committee- Mason Library
- Thursday, July 3rd at 7:30 PM Board of Health- Town Hall
- Tuesday, July 8th at 5:30 PM Republican Town Committee- Town Hall (**date not confirmed**)
- Thursday, July 10th at 5:30 PM Library Board of Trustees- Mason Library
- Thursday, July 10th at 7 PM Planning Board- Town Hall
- Monday, July 14th at 5 PM Parks Commissioners- Mason Library
- Monday, July 14th at 7 PM Selectboard Regular Meeting- Town Hall
- Thursday, July 17th at 2:15 PM GB Housing Authority- Bernard Gibbons Drive
- Thursday, July 17th at 6:30 PM Historic District Commission- Town Hall

Monday, July 21st at 7 PM Selectboard Special Meeting- Town Hall

Wednesday, July 23rd at 6:30 PM Conservation Commission- Town Hall

Thursday, July 24th at 7 PM Planning Board- Town Hall

Monday, July 28th at 7 PM Selectboard Regular Meeting- Town Hall

Wednesday, July 30th at 1:30 PM Council on Aging- Claire Teague Senior Center

BOS SP# 832-14



TOWN OF GREAT BARRINGTON

NOTICE OF PUBLIC HEARING

The Board of Selectmen will hold a public hearing on Monday, June 23, 2014 at 7:00 PM at Town Hall, 334 Main Street, Great Barrington, MA to act on the special permit application of Housatonic Solar 1, 105 Tamara Circle, Avon, CT, for work in the floodplain at 0 Park Street (Map 7, Lot 30), Housatonic, MA, in order to construct a solar array, in accordance with Sections 9.1 and 10.4 of the Great Barrington Zoning Bylaw. The application is on file with the Town Clerk's office.

Sean Stanton, Chairman

Please Publish Friday, May 16, 2014 and Friday, May 23, 2014

Berkshire Record

TOWN OF GREAT BARRINGTON
Application for a Special Permit
to the Board of Selectmen or Planning Board

FORM SP-2
Long Form
REV. 11-2013

FOR OFFICE USE ONLY

Number Assigned 832-14 Date Received 5/2/14
Special Permit Granting Authority BoS
Copy to Recommending Boards 5/6/14
Advertised TBD & TBD
Public Hearing TBD
Fee: \$300.00 Paid: Yes

APPLICATION FOR SPECIAL
PERMIT UNDER TOWN ZONING
BYLAWS FOR TOWN OF
GREAT BARRINGTON,
MASSACHUSETTS

IDENTITY OF PROPERTY: MAP 7 LOT 30 BOOK 667 PAGE 10

Address of property: 0 Park Road

Zoning District(s): Industrial
including any
overlay districts

I. GENERAL INFORMATION

A. Type of Special Permit Requested: Flood Plain Overlay District

Under Section(s) 9.1.4 and 10.4 of the Great
Barrington Zoning Bylaws.

B. Name of applicant: Housatonic Solar 1

C. Address & telephone no. of applicant: 105 Tamara Circle, Avon, CT 06001

D. If applicant is not owner, state interest or status of applicant in land. Attach copy of any option or
purchase agreement. Potential Purchaser

Purchase Agreement Attached

E. Name of owner exactly as it appears on most recent tax bill: Neonah Paper FR, LLC

F. Address of owner: 3460 Preston Ridge Rd, Suite 600, Alpharetta, GA 30005

G. Telephone number of owner: (678) 518-3261

H. Is the proposed development served by :
Public Water System () Yes () No
Public Sewer System () Yes () No

J. Is an environmental study or document required for this project under state or federal laws?
() Yes () No If yes, specify type of study and agency requiring it. Not for the project -
but numerous studies were carried out related to the waste buried onsite.

K. Attach a brief description of proposed use of property, including the existing use of the property,
and how the project is in harmony with the Great Barrington Master Plan. (Copies of the Master

Plan are available for free download from the Town website. Hard copies can be read at the Clerk's office or the Town libraries.)

- L. Attach a list of abutters, owners of land directly opposite on any public or private street or way and owners of land within 300 feet of the property line, including bordering towns. The list must be prepared and certified by the Great Barrington Board of Assessors office.
- M. Include information as applicable in Sections II, III, IV, V, VI and VII.
- N. One original and fourteen (14) exact copies of all required documentation must be submitted.

II. PLAN OF PROPERTY

- A. A site plan for the proposed development, drawn to a scale of 1"=40', each page of which shall be titled, dated, numbered and signed by the preparer. If the preparer is an engineer, architect, surveyor or other professional registered in Massachusetts, *each page shall bear his or her professional seal*. This plan shall clearly show the following:
 - 1. Owner and applicant
 - 2. Engineer or Architect
 - 3. Date
 - 4. Scale and north arrow
 - 5. Zoning district (s)
 - 6. Names of adjacent streets
 - 7. All existing lot lines and dimensions
 - 8. Lot size
 - 9. Locations and dimensions of all existing and proposed structures, including additions thereto
 - 10. Number of dwelling units existing and proposed
 - 11. Location and number of parking spaces, with each space numbered
 - 12. Location of driveways and/or access roads with directional arrows as needed
 - 13. Location of all streams, ponds, wetlands, steep slopes, and other significant topographic features of this property
 - 14. Provisions for drainage, watercourses, easements and systems
 - 15. Existing and proposed uses of structures
 - 16. Screening and/or buffer provisions, as well as all other landscaping proposed
 - 17. Site photos as needed to illustrate the existing and proposed conditions
 - 18. Locus map (locating site within the neighborhood and town)
 - 19. Proposed open space or park area(s) if any
 - 20. Such other data as the Planning Board may require
- B. Other requirements (if and as requested by the Planning Board, Conservation Commission, Board of Selectmen, Board of Health or Building Inspector):
 - 1. General characteristics of land under a separate plan at a scale of 1"=100' showing the general characteristics of all lands within 200 feet of the site including structures, parking areas, driveways, pedestrian ways, natural features and existing land uses. Land uses shall be designated by shading the plan with colored pencil and using standard land use colors.
 - 2. Architectural drawings, prepared by a Registered Architect, at a scale sufficient to show the details of the proposed building (s) and signs but not less than 1/8"=1".
 - 3. A separate plan, prepared by a Registered Engineer or Architect, drawn to a scale of 1"=500' which shall clearly show:
 - a. the project site
 - b. location of public and private wells within 1/2 mile of any lot lines
 - c. Contour lines at 2-foot intervals

- d. Location of wells on the site or within 400 feet of lot lines
- e. Location of wetland area
- 4. Common ownership land/adjacent lots usage.
 - a. A copy of those portions of the Assessors' map(s) showing all contiguous land held in common ownership with the land affected by the special permit, or all contiguous land held in common ownership by the applicant
 - b. Land use of adjacent lots

III. PUBLIC WATER – WASTE DISPOSAL

- A. Availability of public water
 - 1. Estimate demand.
 - 2. Submit documentation of available water pressure.
- B. Availability of public sewer
 - 1. Estimate daily flow of public sewer.
 - 2. Describe disposal facilities and submit evidence of all necessary state and local approvals.
 - 3. Submit evidence of all required approvals by the Massachusetts Department of Environmental Protection of any proposed wastewater treatment system requiring such approval and of any industrial waste treatment or disposal system

IV. ENVIRONMENTAL REPORTS

- A. Submit copies of any environmental reports or documents prepared for the project required by State or Federal law or regulations.
- B. Submit copies of all environmental reports required by the Conservation Commission, Planning Board, Board of Health or any other local board or official.
- C. Description of open space or park(s) if any
 - 1. Letter to the Town of Great Barrington offering open land to the Town, *or*
 - 2. Document showing terms of permanent covenant of open space.
- D. Hazardous Materials
 - 1. A complete list of all materials, pesticides, fuels and toxic or hazardous materials to be used or stored on the premises. Generic names should be supplied as listed in the Massachusetts Department of Protection's Hazardous Waste Regulations (310 CMR 30.000) and, where applicable, the Industry and EPA Hazardous Waste Number should be supplied. The list should be accompanied by a description of measures proposed to protect from vandalism, corrosion, leakage and for control of spills.
 - 2. A description of possible toxic or hazardous wastes to be generated indicating storage and disposal method.

V. PLANNED PHASING

Planned phasing, if project is to be constructed in more than one phase. For multi-family dwellings, cluster residential development and single family attached dwellings, the design of roadways, access roads, sidewalks, common drives, and utilities shall generally conform to the standards set forth in the Rules and Regulations Governing Subdivision of Land in the Town of Great Barrington; regardless of whether the development is a subdivision within the legal definition.

VI. IMPERVIOUS SURFACES

Description of the extent of impervious surfaces, of provisions for collecting surface runoff and of provisions for on-site recharge and removal of contaminants.

VII. GROUNDWATER

Except for those uses applying for a special permit solely for excavating or drilling, a Groundwater Quality Certification, prepared by a Massachusetts Registered Professional Engineer, experienced in hazardous waste disposal, groundwater evaluation or hydrogeology may be required. Said Groundwater Quality Certification shall state that: "as a result of the project, the groundwater quality at the boundary of the premises, resulting from on-site waste disposal, other on-site operations, natural recharge and background water quality,

- a. will not fall below the standards established by the DEP in "Drinking Water Standards in Massachusetts", or
- b. Where existing groundwater quality is already below those standards, will not be further degraded."

Date: 5/1/14

Neenah Paper FG, LLC
by: [Signature]

Owner Signature [Signature]

Co-owner Signature _____

Applicant's Signature [Signature]

SPECIFICS:

- 1. All site plans and specifications must be signed and dated by the preparer.
- 2. **ALL OWNERS** of property must sign the application
- 3. A copy of the special permit procedures is available upon request.
- 4. Fee for application is \$300.00 to cover the cost of the public hearing notices and notification to parties in interest. If the cost exceeds \$300.00, the applicant shall pay the balance due upon notification from the Granting Authority.
- 5. Once all the necessary papers, maps, etc. as indicated above are correlated into seventeen sets, **call the Town Planner's office at 413-528-1619 ext. 7 to arrange an appointment to file your application.** The application will be reviewed for completeness and a date for a public hearing before the Board of Selectmen will be scheduled. Meetings before the recommending Boards such as the Planning Board, Conservation Commission and Board of Health will also be arranged at this time.

PLEASE READ AND SIGN BELOW

ALL COSTS INCURRED BY THE TOWN FOR THE EMPLOYMENT OF EXPERTS OR CONSULTANTS REQUIRED BY ANY TOWN BOARD FOR THE PURPOSE OF ANALYZING OR EVALUATING ANY PROJECT THAT IS A SUBJECT OF A SPECIAL PERMIT APPLICATION SHALL BE ASSESSED TO THE APPLICANT AND SHALL CONSTITUTE PART OF THE APPLICATION FEE. A COPY OF THIS REGULATION SHALL BE PROVIDED TO EACH APPLICANT WHO SHALL SUBMIT WITH HIS APPLICATION A SIGNED STATEMENT THAT HE HAS READ THIS REGULATION AND AGREES TO BE BOUND BY IT.

I have read the above regulation and agree to be bound by it.

Applicant's Signature [Signature]

Date 5/1/14



TOWN OF GREAT BARRINGTON
NOTICE OF PUBLIC HEARING

*Cont to
June 23/14
SB meeting*

The Board of Selectmen will hold a public hearing on Monday, June 9, 2014 at 7:00 PM at Town Hall, 334 Main Street, Great Barrington, MA to act on the special permit application of St. James Place/Fred and Sally Harris, 352 Main Street, Great Barrington, for a community center use in a B-2 zone, deviation from certain parking requirements, and exterior alterations in the Village Center Overlay District, in accordance with Sections 3.1.4 B(6), 6.1, 9.6, and 10.4 of the Great Barrington Zoning Bylaw. The application is on file with the Town Clerk's office.

Sean Stanton, Chairman

Please Publish Friday, May 16, 2014 and Friday, May 23, 2014

Berkshire Record

TOWN OF GREAT BARRINGTON
Application for a Special Permit
to the Board of Selectmen or Planning Board

FORM SP-1
REV. 11-2013

FOR OFFICE USE ONLY

Number Assigned 829-14 Date Received 4/24/14
Special Permit Granting Authority BoS
Copy to Recommending Boards 4/25/14
Advertised 5/16/14 & 5/23/14
Public Hearing 6/9/14
Fee: \$150.00 Paid: Yes

APPLICATION FOR SPECIAL
PERMIT UNDER TOWN ZONING
BYLAWS FOR TOWN OF
GREAT BARRINGTON,
MASSACHUSETTS

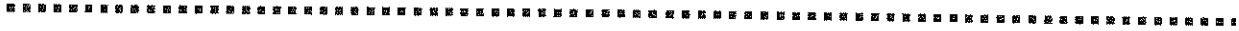

MAP 19 LOT 92 BOOK 2008 PAGE 346 ZONING DISTRICT(S) B-2, VCOB

Site Address: 352 MAIN STREET

APR 24 PM 1:4

Date of Application 4-24-14

Applicant's name and complete mailing address FRED AND SALLY HARRIS

49 LOCUST HILL RD, GREAT BARRINGTON 01230

Applicant's phone number (413) 528-9468 Applicant's email address: Fred@fredharris.com

Name and Address of Owner of land exactly as it appears on most recent tax bill:

SAINT JAMES PLACE

352 MAIN STREET, GREAT BARRINGTON, MA 01230

I (we) request a Special Permits for: community center use in a B-2 zone, exterior changes within the Village Center Overlay District, and deviation from parking requirements.

Under Section(s) 3.1.4 B(6), 9.6.3, 6.1.9 and 10.4 of the Great Barrington Zoning Bylaws.

APPLICANTS MUST READ AND COMPLY WITH THE FOLLOWING:

One Signed Original application with each of the items below, as applicable, and fourteen (14) exact copies of the entire application package are to be submitted. Applications must include:

1. Completed application form, including signatures.
2. Brief written description of how the project is in harmony with the Great Barrington Master Plan. (Copies of the Master Plan are available for free download from the Town website. Hard copies can be read at the Clerk's office or the Town libraries.)
3. Site Plan, drawn to scale, applicable to the site and the proposed use of said site for which this special permit is requested.
4. Any other specifications necessary to further describe the site or proposed use for which a special permit is requested. At least one copy of any maps being submitted shall be no larger than 11" X 17". Plans should show all existing and proposed structures, property lines and dimensions, driveways, walkways and parking areas. All proposed landscaping, parking, loading, and similar improvements must be in compliance with the applicable sections of the Zoning Bylaw.
5. Certified list of abutters within 300' on the Assessors Maps to the subject property, including map and lot number. List must be obtained from the Assessors' Office.

SJP

SAINT JAMES PLACE
352 MAIN STREET GREAT BARRINGTON MA 01230

Christopher Rembold
Town Planner
Town Of Great Barrington
324 Main Street
Great Barrington MA 01230

April 23, 2014

Dear Chris:

I am pleased to submit the attached documents to receive Special Permits to begin the reuse, construction and completion of Saint James Place as a community cultural center.

The Town of Great Barrington and its various operating departments have been supportive and helpful to us in our work to date. The support of the board of selectman helped SJP secure the state and federal historic tax credits, instrumental in project financing as well as creating credibility and viability with our private donors.

Saint James Place has put in place, an architectural and construction team that will transform the former Saint James Church, into a cultural center that will contribute to the town, its citizens, and visitors, now and for future generations

Very Truly

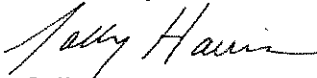

Sally Harris
President

Saint James Place, an overview and description

Saint James Place is A 501(c)(3) secular nonprofit organization located in the town of Great Barrington. Saint James Place (SJP) builds on the world-renowned cultural landscape of Berkshire County by creating a state-of-the-art community cultural center that serves the needs of both residents and visitors.

There are few places in the country that integrate the arts seamlessly into everyday life than the Berkshires. It is a prime example of a community successfully employing the arts as a creator of community and as an economic engine. Sally and Fred Harris, local residents dedicated to supporting both the cultural and community needs of the region, founded SJP in 2010. This former Episcopal church located on Main Street in the heart of Great Barrington is currently being transformed into a year-round community cultural facility featuring space for music and theatrical performances, educational events and civic functions.

SJP's programs and services include:

- music performances and community cultural events that are organized and produced by SJP itself, with a particular focus on early music;
- cultural performances produced by local nonprofit arts organizations that do not have their own space and rent SJP's facilities for their offices, events and performances; and
- community-building activities for other nonprofit organizations.

When SJP acquired the building in September 2010, it began receiving inquiries from local non-profit arts organization interested in using the space. There is currently no facility in the area that matches SJP in size, location or excellent acoustics. We conducted a market study in 2013 to determine the capital needs of local arts organizations and identified live music performance as a key area needing expansion in the region. To that end, we have spoken with many music organizations that confirmed a local need for mid-size or small performance venues in which to hold concerts. These organizations, including Aston Magna Music Festival, Close Encounters with Music, Berkshire Children's Chorus and Berkshire Bach, have all expressed interest in using SJP's performance spaces once they are renovated.

SJP's programs and services include:

- music performances and community cultural events that are organized and produced by SJP itself, with a particular focus on early music;
- cultural performances produced by local nonprofit arts organizations that do not have their own space and rent SJP's facilities for their offices, events and performances; and
- community-building activities for other nonprofit organizations.

SJP is also committed to local theatre companies like Berkshire Playwrights Lab and Berkshire Fringe, whose size precludes them from owning their own performance facilities, as well as local schools such as Berkshire Community College and Rudolf

Steiner School, who are interested in using the space for theatrical and music activities. SJP is also committed to bringing new theater and music partners from outside the region, including institutes of higher education (Yale School of Music, the Berklee School of Music, and the Curtis Institute of Music), theater companies (HERE Arts Center in NYC), and other groups to improve local cultural diversity.

Our audience represents a wide range of demographic and geographic characteristics, drawing from the art-attending public that visits the Berkshires every year, as well as local residents, second home owners, and visitors. While local audiences tend to be older, SJP's more avant-garde offerings and affordable tickets will draw from a younger and more culturally current population. There is also significant potential for SJP's programming to draw and extend tourist stays in the Berkshires.

St. James Place, 352 Main Street, Great Barrington

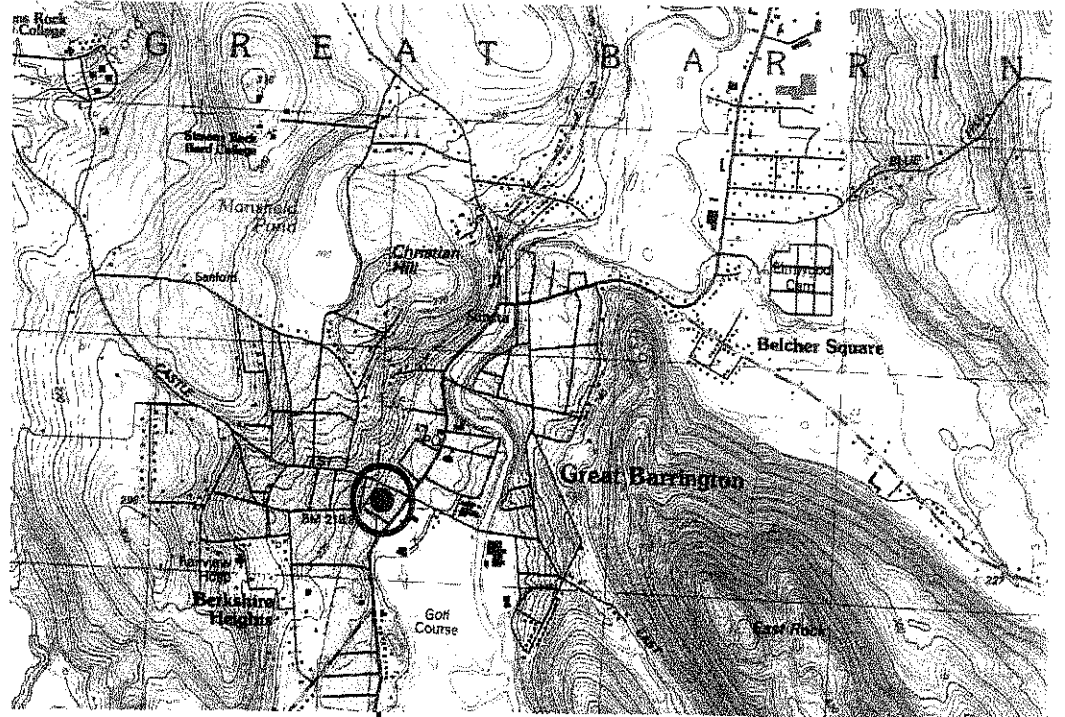

Great Barrington Village

200 115 5 200 400 800 Feet

1:7,000

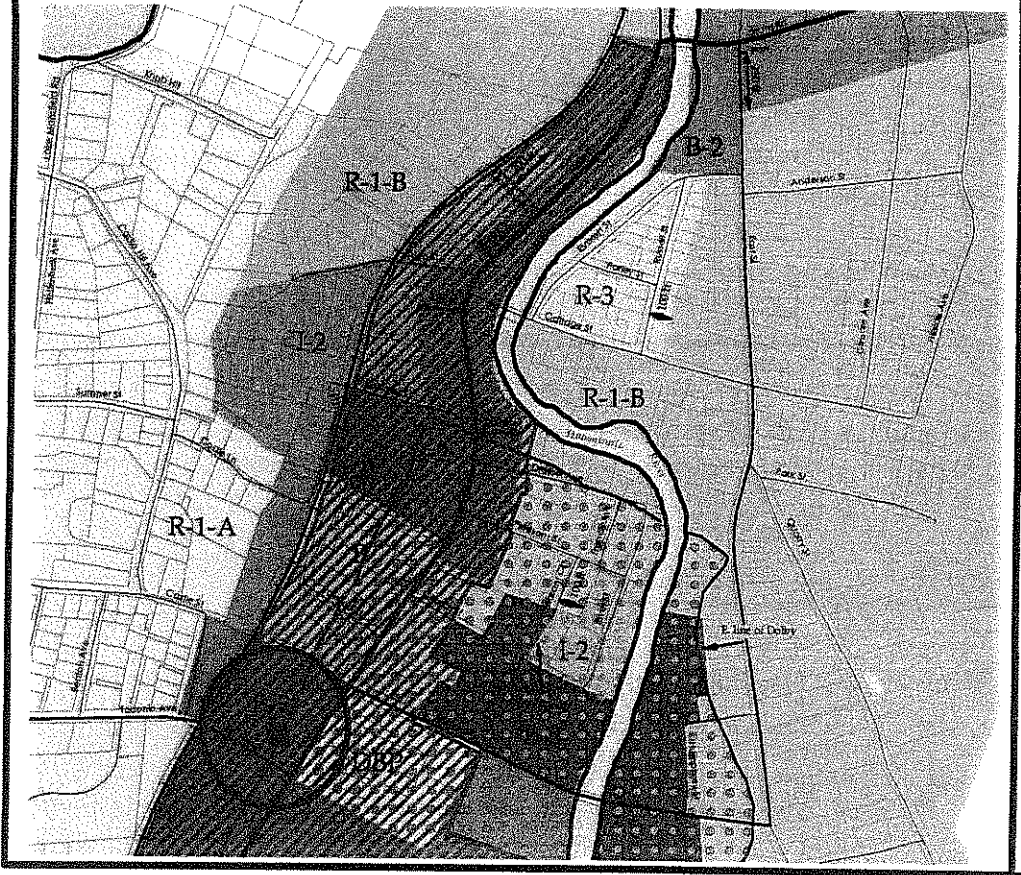

SB meeting - 6/9/14 Con. + to SB meeting 6/23/14
 Town of Great Barrington
 Board of Selectmen

Form date: June 2011

Fee \$50.00 (pd)

Application for Access to a Public Way / Driveway Permit

Number _____

INSTRUCTIONS

RETURN FIVE (5) COPIES OF THIS FORM AND ALL ACCOMPANYING PLANS, ALONG WITH THE \$50.00 FEE to the Department of Public Works office in Town Hall, 2nd Floor, 334 Main Street, Great Barrington, MA 01230. Plans must show the location of the driveway on the property and must also indicate all details needed in order to determine that driveway regulations are met, including paving material, width, grade, drainage, culverts, angle to street, etc. See Chapter 153 of the Town Code for driveway regulations.

Application Date 5/21/14
 Name of Applicant / Property Owner LYNN A. HUTCHINSON
 Mailing address 40 KELLY, GRANGER + PARSONS, P.O. Box 88, GREAT BARR., 01230
 Phone number 413 - 528 - 3291
 Location of proposed driveway / highway entrance WEST SIDE OF LONG POND ROAD NORTH SIDE OF ASSESSOR MAP 33, LOT 3
 Contractor who will perform the work T B D
 Address & phone number of contractor T B D
 Proposed construction date T B D
 Type of driveway (gravel, asphalt, etc.) GRAVEL

Print Form

Submit five (5) copies of completed form and plans.

Applicant hereby agrees to notify the Great Barrington DPW Superintendent of the date and time of driveway construction at least 24 hours before construction is begun. Applicant further agrees to conform to all requirements of the Town of Great Barrington regulations governing access to public ways and to all conditions that may be placed on this permit. See Chapter 153 of the Town Code for regulations and design requirements.

Applicant's Signature: Lynn Hutchinson by Charles Parsons

FOR STAFF USE ONLY

RECOMMENDATION OF DPW / HIGHWAY SUPERINTENDENT

After consultation with review staff, and after full consideration of the application and the applicable requirements, I recommend that this application be:

- approved as submitted
- approved with conditions attached
- disapproved for reasons attached
- resubmitted with changes suggested per attached

Staff Reviews Received:

	Received	Conditions Recommended	Other Permits Required
Conservation:	<input checked="" type="checkbox"/>	<input type="checkbox"/>	<input type="checkbox"/>
Fire Chief:	<input checked="" type="checkbox"/>	<input type="checkbox"/>	<input type="checkbox"/>
Planning:	<input checked="" type="checkbox"/>	<input type="checkbox"/>	<input type="checkbox"/>

PERMIT FOR ACCESS TO A PUBLIC WAY / DRIVEWAY

Pursuant to its vote of _____ in favor and _____ opposed, at its meeting on _____, the Great Barrington Board of Selectmen granted permission to construct or alter this access to a public way at the address and in the location indicated in this application, in accordance with the plans accompanying this application, and subject to any conditions attached.

For the Selectmen: _____, its _____ (signature) (title) (date)

Pete Soules
Highway-Facilities Superintendent

E-mail: psoules@townofgb.org
www.townofgb.org



20 East Street
Great Barrington, MA 01230

Telephone: (413) 528-2500
Fax: (413) 528-2290

TOWN OF GREAT BARRINGTON MASSACHUSETTS

Department of Public Works
Highway Division

Conditions on Application for Access to Public Way

Applicant: Lynn A. Hutchinson
Location: 263 Long Pond Road
From: Pete Soules Highway Superintendent 
Date: 5/30/2014

1. The applicant shall construct the proposed access to conform to the following applicable criteria listed under **Section 153-14, Design requirements** of the Town of Great Barrington Code:
 - B. Driveway location as shown on the attached plan is acceptable, with regards to alignments with the way, profile, sight distance conditions and not located at the extreme edge of the property.
 - C. No more than two (2) driveways shall normally be allowed for any property, unless there is a clear necessity for more.
 - D. Driveways shall not normally be approved at intersections, because of potential safety hazards.
 - E. Culverts taking the place of roadside ditches shall have a diameter of not less than 15" (*A culvert is not required at this location*)
 - F. Entrance elevation at the point of entry into the public right-of-way shall be no more than the elevation of the shoulder of the road.
 - G. Driveways should be so constructed that water from the driveway shall not drain onto the crown of the road.
 - H. In no instance shall the edge of the driveway entering onto the road conflict with the flow of surface water runoff.

- I. Driveway width shall not be less than 8-feet or more than 16-feet within the town right-of-way. Any curb at the entrance shall be rounded off with a radius of three (3) feet.
 - J. Pitch of driveway shall be downward from the edge of the road to sideline of the town right-of-way or front property line.
 - K. Driveways should be located to the best advantage with respect to the alignment with the way, profile and sight distance conditions. In no instance shall a driveway intersect the way at less than a sixty degree angle. Unless there is no alternative, a driveway should not be located within a required side yard.
 - L. No permit shall be issued for any driveway to a structure or proposed structure on a grade in excess of ten percent (10%) above the road or street level until and unless the applicant submits plans to the Highway Superintendent showing that the driveway will be constructed in a such a way so as not to discharge water, stones or other materials onto any public street, road or highway.
2. Install a paved driveway apron in accordance with the following requirements:
 - A. Apron dimensions: Width = 22-feet maximum along the roadway which includes a 3-foot radius curb on each side. Length = 5-feet minimum from edge of roadway. *(Apron shall have a 1-1/2" rise above edge of road surface)*
 - B. Place 3-inches of bituminous concrete on 12-inches of compacted gravel.
 - C. Place asphalt tack coat along the edge of the road where the apron meets the edge of the existing pavement.

The applicant agrees to notify the Highway Superintendent (528-2500) at least 48 hours prior to the installation of the paved apron.

3. Should there be, after completion of the driveway, discharges of water, stones, or silt onto the public way or onto property of any abutters or neighbors, the property owner shall take whatever steps are necessary to eliminate such discharges.
4. The applicant shall maintain the proposed access to conform to the following applicable condition listed under **Section 153-17, Continuing responsibility of owners**, of the Town of Great Barrington Code:

Abutting property owners shall be responsible for keeping culverts under their driveways cleared and for maintaining driveways in condition conforming to the requirements of the permit.

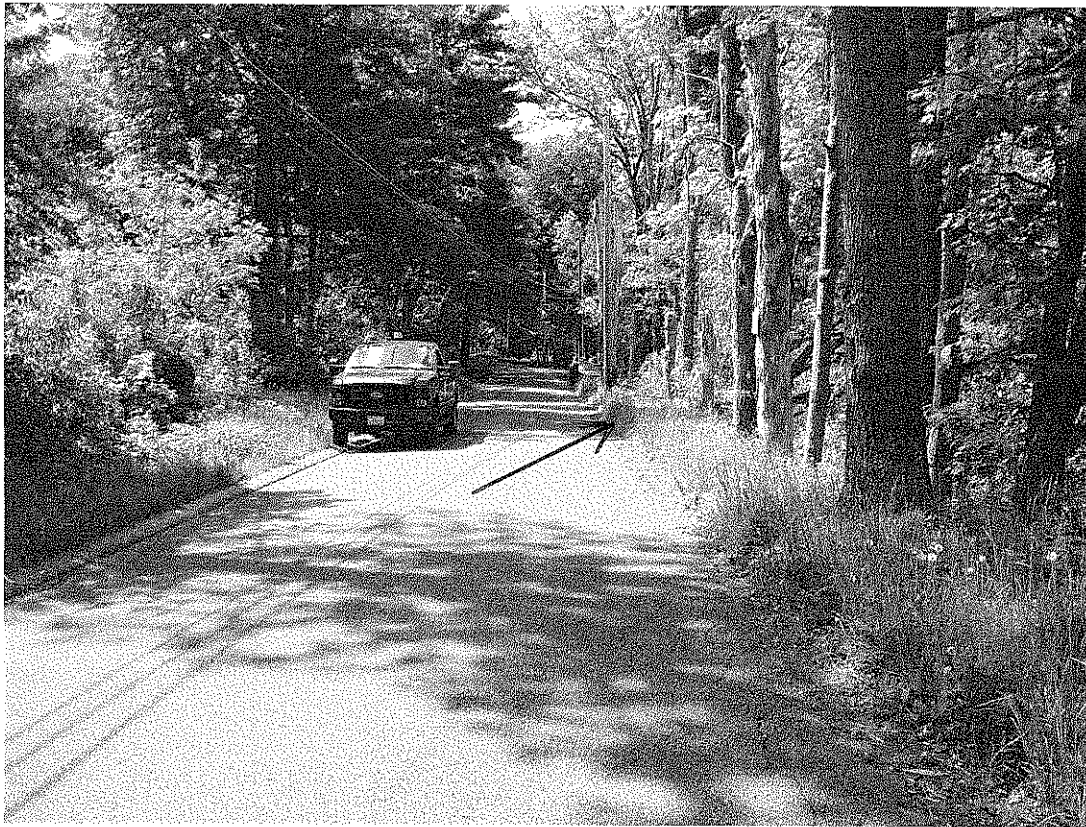

263 Long Pond Road
Looking South

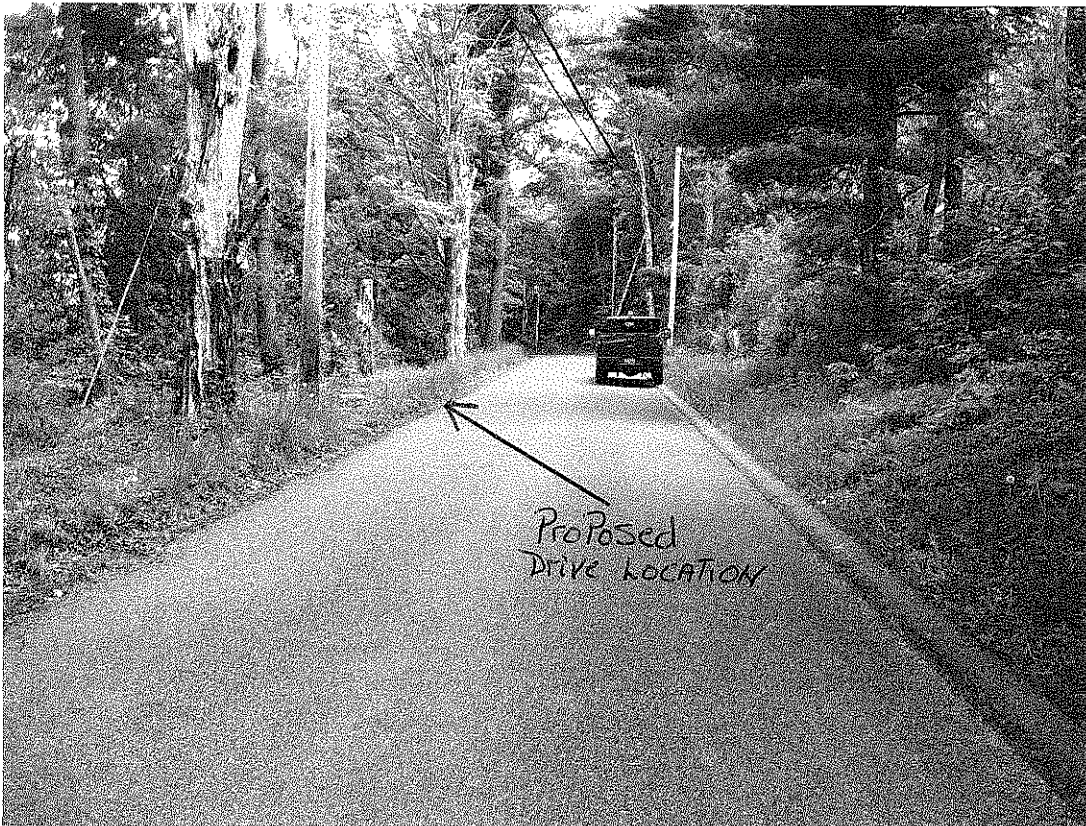

263 Long Pond Road
Looking North

Joan Johnsen

From: Chris Rembold
Sent: Wednesday, June 04, 2014 12:24 PM
To: Joseph Sokul; Joan Johnsen
Subject: Driveway permit - Hutchinson

I have reviewed this driveway permit and see no planning issues.

Thank you.

Christopher T. Rembold, AICP

Town Planner
Town of Great Barrington
334 Main Street
Great Barrington, MA 01230
Ph: (413) 528-1619, x. 7
www.townofgb.org

Joan Johnsen

From: Charles Burger
Sent: Wednesday, June 04, 2014 1:52 PM
To: Joan Johnsen
Subject: RE: Hutchinson Driveway Application

Thanks. There are no problems for the Fire Department.

Charles Burger
Chief, Great Barrington Fire Department
37 State Rd.
Great Barrington, MA 01230
Phone: 413-528-0788
Fax: 413-528-8315

From: Joan Johnsen
Sent: Wednesday, June 04, 2014 1:47 PM
To: Charles Burger
Subject: RE: Hutchinson Driveway Application

Sure, no problem. Attached above.

Joan Johnsen
Administrative Assistant
DPW/Town Planner
(413) 528-1619 xt. 109
(413) 528-2290 fax

jjohnsen@townofgb.org

From: Charles Burger
Sent: Wednesday, June 04, 2014 1:20 PM
To: Joan Johnsen
Subject: RE: Hutchinson Driveway Application

No it doesn't. Sorry. Can you scan a copy? Sorry!

Charles Burger
Chief, Great Barrington Fire Department
37 State Rd.
Great Barrington, MA 01230
Phone: 413-528-0788
Fax: 413-528-8315

From: Joan Johnsen
Sent: Wednesday, June 04, 2014 1:18 PM
To: Charles Burger
Subject: RE: Hutchinson Driveway Application

Charlie,

Joseph Sokul
DPW Superintendent

E-mail: jsokul@townofgb.org
www.townofgb.org



Town Hall, 334 Main Street
Great Barrington, MA 01230

Telephone: (413) 528-0867
Fax: (413) 528-2290

TOWN OF GREAT BARRINGTON MASSACHUSETTS

DEPARTMENT OF PUBLIC WORKS

MEMORANDUM

Date: May 22, 2014

To: Joseph Sokul, DPW Superintendent
Peter Soules, Highway Superintendent
Christopher Rembold, Town Planner
Shep Evans, Conservation Commission Agent
Charlie Burger, Fire Chief

From: Joan Johnsen, Admin. Assistant

Re: Driveway Permit Application for
Name: Lynn A. Hutchinson

Location: West side of Long Pond Road. North side of Assessor Map 33, Lot 3

Attached please find a Driveway Permit application for the property listed above. Please review and comment at your earliest convenience. We would like to place this permit on the Selectmen's Agenda for June 9th, 2014.

Thank you.

*Outside Cons Comm jurisdiction;
not regulated by Wetlands
Protection Act or State
Mountain Act. No further
comment. Shepley Evans
SHEPLEY EVANS
Conservation Agent
5-22-2014*

THIS PARCEL IS SUBJECT TO AND WITH THE BENEFIT OF ALL RIGHTS, RESTRICTIONS, CONDITIONS, EASEMENTS, LEASES, ENCUMBRANCES AND APPURTENANCES OF RECORD.

RECORD OWNER: LYNN A. HUTCHINSON
LOCUS DEED: BK - 2204 PG - 344

IRON PIPE FOUND

15'±

90'±

ASSESSOR MAP #33
LOT 3A

PROPERTY LINE

ASSESSOR MAP #33
LOT 3

PROPOSED DRIVEWAY TO
CONNECT TO EXISTING DRIVEWAY

APPROX. SIDELINE

EXISTING
PARKING

EXISTING DRIVEWAY

EXISTING DRIVEWAY



Scale 1" = 30'

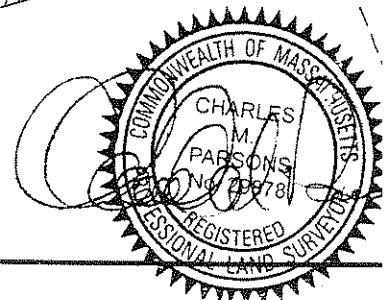

PROPOSED 15" CULVERT
(REQUIRED BY TOWN)

PROPOSED GRAVEL DRIVEWAY ENTRANCE
MAX. 16' WIDTH (WITHIN TOWN RIGHT OF WAY)
WITH 3' CURB RADIUS AT EDGE OF LONG POND ROAD

PROPOSED DRIVEWAY TO GENERALLY FOLLOW
EXISTING GRADE AND ANY SURFACE WATER IS
TO DRAIN AWAY FROM LONG POND ROAD AND
FOLLOW EXISTING DRAINAGE PATTERNS.

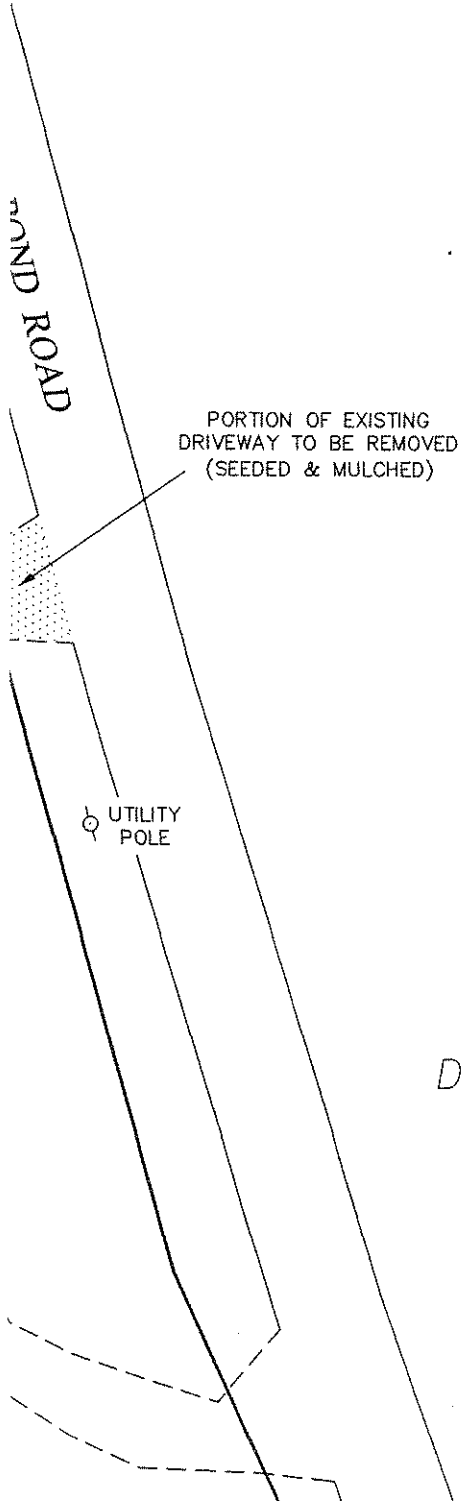
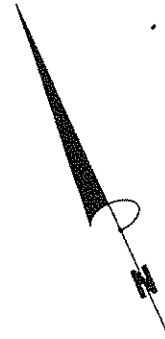

PORTION OF EXISTING
DRIVEWAY TO BE REMOVED
(SEEDED & MULCHED)

UTILITY
POLE

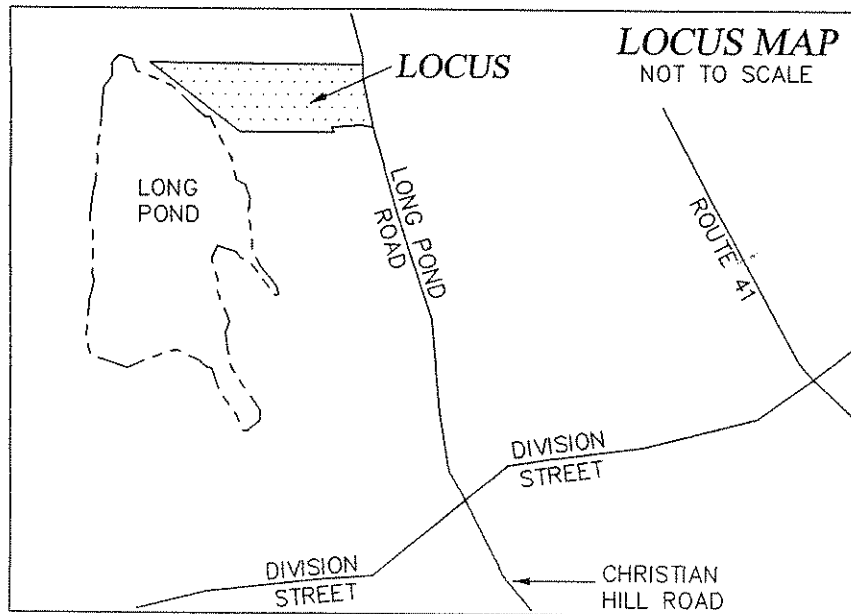

LOCUS MAP
NOT TO SCALE

DRIVEWAY PERMIT SITE PLAN PREPARED FOR
LYNN A. HUTCHINSON

GREAT BARRINGTON, MASSACHUSETTS

MAY - 2014 SCALE 1" = 30'

KELLY, GRANGER, PARSONS & ASSOCIATES, INC.

PROFESSIONAL LAND SURVEYORS

312 MAIN STREET P.O. BOX 88

GREAT BARRINGTON, MASSACHUSETTS 01230

FAX (413) 528-1912

PHONE (413) 528-3291

File name: C:\EP14\SURVEY\SCHW514



RECEIVED
TOWN MANAGER

JUN 11 2014

BOARD OF SELECTMEN
GREAT BARRINGTON, MA

TOWN OF GREAT BARRINGTON
Temporary Weekday Entertainment License Application

\$25.00 per day x 2 = \$50.00 total (pd)

The undersigned hereby applies for a license in accordance with the provisions of MA General Laws, Ch.140 Sec.183A amended, Ch.351, Sec.85 of Acts of 1981 and Ch.140 Sec.181.

Name: RICHARD KOTHBAED
Business/Organization: AMERICAN ART MARKETING
D/B/A (if applicable): BERKSHIRES ARTS FESTIVAL
Address: SKI BUTTERNUT 380 STATE RD 23 GT BARRINGTON.
Mailing Address: P.O BOX 480 SLATE HILL, NY 10973
Phone Number: 845.355.2400 845.661.1221 CELL

TYPE: (Check all that apply) Concert Dance Exhibition Cabaret DJ

Live band with up to 4 pieces, including singers Public Show

Other (please explain) _____

INCLUDES: Live music Recorded music Dancing by entertainers/ performers

Dancing by patrons Amplification system Theatrical exhibition

Floorshow Play Moving picture show Light show Jukebox

Other (please explain) _____ 4 PC. BLUES BAND

As part of the entertainment, will any person be permitted to appear on the premises in any manner or attire as to expose to public view any portion of the pubic area, anus, or genitals, or any simulation thereof, or whether any person will be permitted to appear on the premises in any manner or attire as to expose to public view a portion of the breast below the top of the areola, or any simulation thereof? (M.G.L.Chp.140 Sec.183A)

____ YES

NO

Please circle: INDOOR or OUTDOOR Entertainment

Exact Location of Entertainment (include sketch): INSIDE TENT.

WHEEL PATRONS PINE

Date(s) of Entertainment*: JULY 4, 5, 2014

*Does not include SUNDAY

Start & End Times of Entertainment: START 1 PM - 3 PM

ALL entertainment licenses will be reviewed by the Design Review Team (DRT), which is comprised of several Town departments, for comments/concerns on this application.

Pursuant to M.G.L. Ch. 62C, Sec. 49A, I certify under the penalties of perjury that I, to my best knowledge and belief, have filed all state tax returns and paid all state taxes required under law.

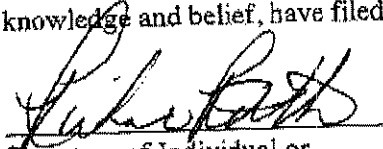
Signature of Individual or
Corporate Officer

6.10.14
Date

SS# or FID#

TOWN USE ONLY:

DRT Review with Conditions: No issues. Tent & sign permits
already obtained.

APPROVAL DATE: _____

LICENSE # _____

Berkshires Art Festival 2013

Ski Butternut, Route 23

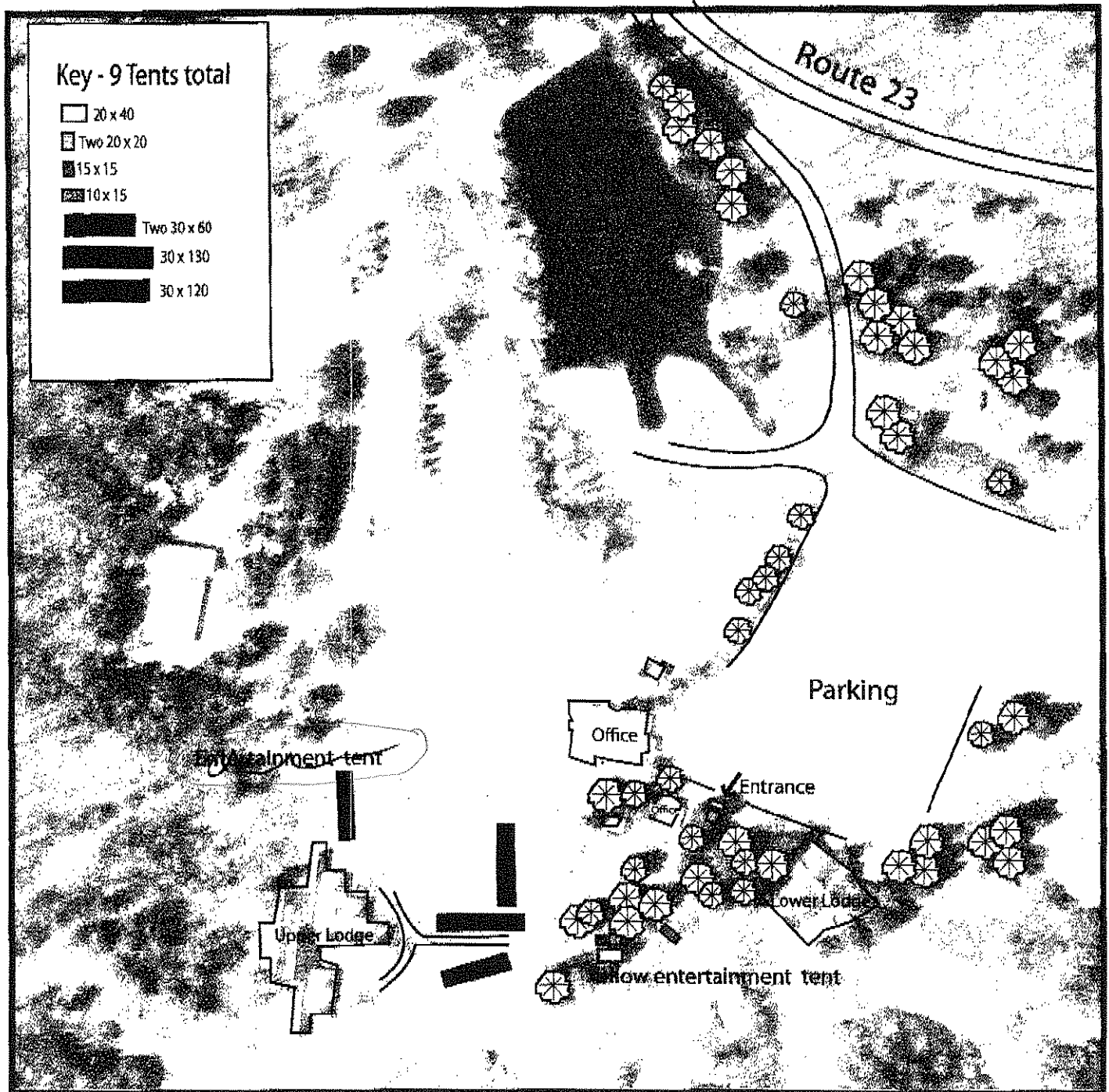

Jennifer Bailly

From: joanna@americanartmarketing.com
Sent: Wednesday, June 11, 2014 12:53 PM
To: Jennifer Bailly
Subject: Re: Fees for Entertainment Licenses

Hi Jennifer,
We will be in the Berkshires tomorrow so I will stop in with the checks.
We will not be able to attend the meeting.

Thank You!
Joanna

Joanna Rothbard
joanna@americanartmarketing.com

AMERICAN ART MARKETING

PO Box 480
Slate Hill NY 10973

phone: (845) 355-2400
fax: (845) 355-2333

www.americanartmarketing.com
www.anamericancraftsman.com



On Jun 11, 2014, at 11:29 AM, Jennifer Bailly wrote:

Joanna,

I just got your Temporary Weekday & Sunday entertainment licenses for the Berkshire Arts Festival in July. The fee breakdown is below:

Temp Weekday Ent License:

July 4 & 5- \$50.00 total (\$25.00 each)

Temp Sunday Ent License:

July 6- \$2.00 Town of Great Barrington

Jennifer Bailly

From: daver <daver@skibutternut.com>
Sent: Wednesday, June 11, 2014 3:56 PM
To: Jennifer Bailly
Subject: Ski Butternut Art Fest

Dear Selectmen,

Please be advised the Ski Butternut approves of any and all entertainment planned for the 13th annual Berkshire Arts Festival that is scheduled to occur at Ski Butternut, 380 State Road - Rt 23, Great Barrington, Massachusetts on Friday, 7/4/14; Saturday, 7/5/14; and Sunday, 7/6/14.

If you have any questions whatsoever, please do not hesitate to call (or email) me. Thank you for your anticipated cooperation in supporting this great event for the town.

--

Sincerely,

David P. Ryel
Ski Butternut
Event Manager
413-528-2000 x154

Jennifer Bailly

From: Joseph Sokul
Sent: Monday, June 16, 2014 7:30 AM
To: Chris Rembold; Charles Burger; Edwin May; Great Barrington Conservation Commission; Mark Pruhenski; William Walsh
Cc: Jennifer Bailly
Subject: RE: Arts Market at Butternut

No issues with DPW

From: Chris Rembold
Sent: Friday, June 13, 2014 12:14 PM
To: Charles Burger; Chris Rembold; Edwin May; Great Barrington Conservation Commission; Joseph Sokul; Mark Pruhenski; William Walsh
Cc: Jennifer Bailly
Subject: Arts Market at Butternut

DRT,

Any issues with the annual Berkshire Arts Market at Ski Butternut? This year it will be July 4, 5, and 6. Includes artists and entertainment as usual in the lawns around the main lodge.

Please let me know.

Christopher T. Rembold, AICP
Town Planner
Town of Great Barrington
334 Main Street
Great Barrington, MA 01230
Ph: (413) 528-1619, x. 7
www.townofgb.org

Jennifer Bailly

From: Mark Pruhenski
Sent: Friday, June 13, 2014 12:21 PM
To: Chris Rembold
Cc: Charles Burger; Edwin May; Great Barrington Conservation Commission; Joseph Sokul; William Walsh; Jennifer Bailly
Subject: Re: Arts Market at Butternut

No issues with Health.....the food vendors are the same every year and they all know the drill. -m

Sent from my iPhone

On Jun 13, 2014, at 12:13 PM, "Chris Rembold" <crembold@Townofgb.org> wrote:

DRT,

Any issues with the annual Berkshire Arts Market at Ski Butternut? This year it will be July 4, 5, and 6. Includes artists and entertainment as usual in the lawns around the main lodge.

Please let me know.

Christopher T. Rembold, AICP
Town Planner
Town of Great Barrington
334 Main Street
Great Barrington, MA 01230
Ph: (413) 528-1619, x. 7
www.townofgb.org

Jennifer Bailly

From: William Walsh
Sent: Tuesday, June 17, 2014 1:48 PM
To: Jennifer Bailly
Subject: RE: Arts Market at Butternut

No issues

From: Jennifer Bailly
Sent: Tuesday, June 17, 2014 1:20 PM
To: Charles Burger; Edwin May; Great Barrington Conservation Commission; William Walsh
Cc: Helen Kuziemko
Subject: FW: Arts Market at Butternut
Importance: High

Hello!

I have not seen any emails back from you guys regarding the above entertainment event at Butternut. If you have replied back to Chris R. ONLY, can you please forward this response to Helen and I. Chris is on vacation this week and this is on the Selectboard's agenda for June 23. We need your responses back as soon as possible. Thank you!

Jenn

From: Chris Rembold
Sent: Friday, June 13, 2014 12:14 PM
To: Charles Burger; Chris Rembold; Edwin May; Great Barrington Conservation Commission; Joseph Sokul; Mark Pruhenski; William Walsh
Cc: Jennifer Bailly
Subject: Arts Market at Butternut

DRT,

Any issues with the annual Berkshire Arts Market at Ski Butternut? This year it will be July 4, 5, and 6. Includes artists and entertainment as usual in the lawns around the main lodge.

Please let me know.

Christopher T. Rembold, AICP
Town Planner
Town of Great Barrington
334 Main Street
Great Barrington, MA 01230
Ph: (413) 528-1619, x. 7
www.townofgb.org

Jennifer Bailly

From: Great Barrington Conservation Commission
Sent: Tuesday, June 17, 2014 3:46 PM
To: Chris Rembold
Cc: Jennifer Bailly; Helen Kuziemko
Subject: RE: Arts Market at Butternut

No Conservation Issues on this one.
-Shep

From: Chris Rembold
Sent: Friday, June 13, 2014 12:14 PM
To: Charles Burger; Chris Rembold; Edwin May; Great Barrington Conservation Commission; Joseph Sokul; Mark Pruhenski; William Walsh
Cc: Jennifer Bailly
Subject: Arts Market at Butternut

DRT,

Any issues with the annual Berkshire Arts Market at Ski Butternut? This year it will be July 4, 5, and 6. Includes artists and entertainment as usual in the lawns around the main lodge.

Please let me know.

Christopher T. Rembold, AICP
Town Planner
Town of Great Barrington
334 Main Street
Great Barrington, MA 01230
Ph: (413) 528-1619, x. 7
www.townofgb.org

Jennifer Bailly

From: Charles Burger
Sent: Tuesday, June 17, 2014 5:01 PM
To: Jennifer Bailly; Edwin May; Great Barrington Conservation Commission; William Walsh
Cc: Helen Kuziemko
Subject: RE: Arts Market at Butternut

No problems for the FD

Charles Burger
Chief, Great Barrington Fire Department
37 State Rd.
Great Barrington, MA 01230
Phone: 413-528-0788
Fax: 413-528-8315

From: Jennifer Bailly
Sent: Tuesday, June 17, 2014 1:20 PM
To: Charles Burger; Edwin May; Great Barrington Conservation Commission; William Walsh
Cc: Helen Kuziemko
Subject: FW: Arts Market at Butternut
Importance: High

Hello!

I have not seen any emails back from you guys regarding the above entertainment event at Butternut. If you have replied back to Chris R. ONLY, can you please forward this response to Helen and I. Chris is on vacation this week and this is on the Selectboard's agenda for June 23. We need your responses back as soon as possible. Thank you!

Jenn

From: Chris Rembold
Sent: Friday, June 13, 2014 12:14 PM
To: Charles Burger; Chris Rembold; Edwin May; Great Barrington Conservation Commission; Joseph Sokul; Mark Pruhenski; William Walsh
Cc: Jennifer Bailly
Subject: Arts Market at Butternut

DRT,

Any issues with the annual Berkshire Arts Market at Ski Butternut? This year it will be July 4, 5, and 6. Includes artists and entertainment as usual in the lawns around the main lodge.

Please let me know.

Christopher T. Rembold, AICP
Town Planner
Town of Great Barrington
334 Main Street
Great Barrington, MA 01230
Ph: (413) 528-1619, x. 7
www.townofgb.org

Jennifer Bailly

From: Edwin May
Sent: Wednesday, June 18, 2014 7:00 AM
To: Helen Kuziemko; Jennifer Bailly
Subject: FW: Arts Market at Butternut

From: Edwin May
Sent: Monday, June 16, 2014 7:15 AM
To: Chris Rembold
Subject: RE: Arts Market at Butternut

Tent and sign permits have been filed for and issued.

From: Chris Rembold
Sent: Friday, June 13, 2014 12:14 PM
To: Charles Burger; Chris Rembold; Edwin May; Great Barrington Conservation Commission; Joseph Sokul; Mark Pruhenski; William Walsh
Cc: Jennifer Bailly
Subject: Arts Market at Butternut

DRT,

Any issues with the annual Berkshire Arts Market at Ski Butternut? This year it will be July 4, 5, and 6. Includes artists and entertainment as usual in the lawns around the main lodge.

Please let me know.

Christopher T. Rembold, AICP
Town Planner
Town of Great Barrington
334 Main Street
Great Barrington, MA 01230
Ph: (413) 528-1619, x. 7
www.townofgb.org

JUN 11 2014

BOARD OF SELECTMEN
GREAT BARRINGTON, MA



TOWN OF GREAT BARRINGTON
Temporary ~~Sunday~~ Entertainment License Application
(Local Approval ONLY-State Approval Required Separately)

Hours between 1:00 pm-11:59 pm (pd) (\$2.00 per Sunday) Hours between 9:00 am- 11:59 pm (\$5.00 per Sunday)

The undersigned hereby applies for a license in accordance with the provisions of Massachusetts General Laws, Ch.136 Sec.4.

Name: RICHARD ROTHBARD
Business/Organization: AMERICAN ART MARKETING
D/B/A (if applicable): BERKSHIRES ARTS FESTIVAL
Address: SKI BUTTERNUT 380 STATE RD RT 23
Mailing Address: P.O. BOX 480 SLATE HILL, NY 10973
Phone Number: 845.661.1221 CEL 845.355.2400 OFFICE

TYPE: (Check all that apply) Concert Dance Exhibition Cabaret DJ
 Live band with up to 4 pieces, including singers Public Show
 Other (please explain) _____

INCLUDES: Live music Recorded music Dancing by entertainers/ performers
 Dancing by patrons Amplification system Theatrical exhibition
 Floorshow Play Moving picture show Light show Jukebox
 Other (please explain) JAZZ TRIO, 4 PC BLUES BAND

As part of the entertainment, will any person be permitted to appear on the premises in any manner or attire as to expose to public view any portion of the pubic area, anus, or genitals, or any simulation thereof, or whether any person will be permitted to appear on the premises in any manner or attire as to expose to public view a portion of the breast below the top of the areola, or any simulation thereof? (M.G.L. Chp.140 Sec.183A)

___ YES

NO

Please circle: INDOOR or **OUTDOOR** Entertainment

Exact Location of Entertainment (include sketch): _____

SEE ATTACHED

Date(s) of Entertainment: Sunday, JULY 6, 2014

Start & End Times of Entertainment: 1-3 PM

ALL entertainment licenses will be reviewed by the Design Review Team (DRT), which is comprised of several Town departments, for comments/concerns on this application.

Pursuant to M.G.L. Ch. 62C, Sec. 49A, I certify under the penalties of perjury that I, to my best knowledge and belief, have filed all state tax returns and paid all state taxes required under law.

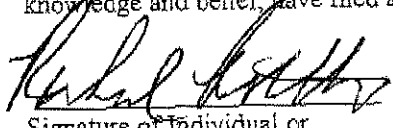

Signature of Individual or Corporate Officer

6-10-14
Date

SS# or FID#

TOWN USE ONLY:

DRT Review with Conditions: No issues. Tent and sign permits already obtained.

APPROVAL DATE: _____

LICENSE # _____

Berkshires Art Festival 2013

Ski Butternut, Route 23

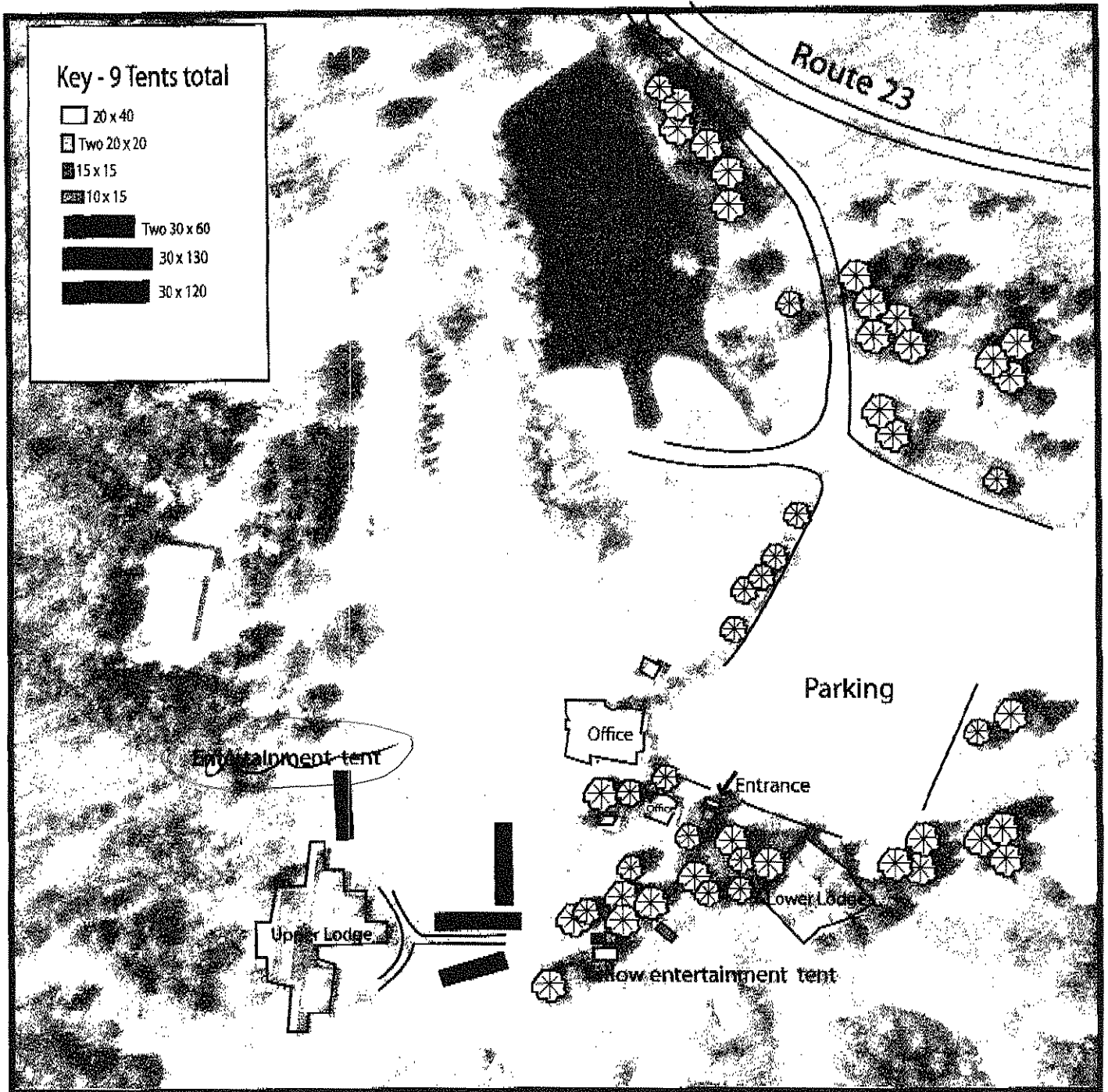

Jennifer Bailly

From: joanna@americanartmarketing.com
Sent: Wednesday, June 11, 2014 12:53 PM
To: Jennifer Bailly
Subject: Re: Fees for Entertainment Licenses

Hi Jennifer,

We will be in the Berkshires tomorrow so I will stop in with the checks.

We will not be able to attend the meeting.

Thank You!

Joanna

Joanna Rothbard

joanna@americanartmarketing.com

AMERICAN ART MARKETING

PO Box 480
Slate Hill NY 10973

phone: (845) 355-2400

fax: (845) 355-2333

www.americanartmarketing.com

www.anamericancraftsman.com



On Jun 11, 2014, at 11:29 AM, Jennifer Bailly wrote:

Joanna,

I just got your Temporary Weekday & Sunday entertainment licenses for the Berkshire Arts Festival in July. The fee breakdown is below:

Temp Weekday Ent License:

July 4 & 5- \$50.00 total (\$25.00 each)

Temp Sunday Ent License:

July 6- \$2.00 Town of Great Barrington

Jennifer Bailly

From: daver <daver@skibutternut.com>
Sent: Wednesday, June 11, 2014 3:56 PM
To: Jennifer Bailly
Subject: Ski Butternut Art Fest

Dear Selectmen,

Please be advised the Ski Butternut approves of any and all entertainment planned for the 13th annual Berkshire Arts Festival that is scheduled to occur at Ski Butternut, 380 State Road - Rt 23, Great Barrington, Massachusetts on Friday, 7/4/14; Saturday, 7/5/14; and Sunday, 7/6/14.

If you have any questions whatsoever, please do not hesitate to call (or email) me. Thank you for your anticipated cooperation in supporting this great event for the town.

--

Sincerely,

David P. Ryel
Ski Butternut
Event Manager
413-528-2000 x154

Jennifer Bailly

From: Joseph Sokul
Sent: Monday, June 16, 2014 7:30 AM
To: Chris Rembold; Charles Burger; Edwin May; Great Barrington Conservation Commission; Mark Pruhenski; William Walsh
Cc: Jennifer Bailly
Subject: RE: Arts Market at Butternut

No issues with DPW

From: Chris Rembold
Sent: Friday, June 13, 2014 12:14 PM
To: Charles Burger; Chris Rembold; Edwin May; Great Barrington Conservation Commission; Joseph Sokul; Mark Pruhenski; William Walsh
Cc: Jennifer Bailly
Subject: Arts Market at Butternut

DRT,

Any issues with the annual Berkshire Arts Market at Ski Butternut? This year it will be July 4, 5, and 6. Includes artists and entertainment as usual in the lawns around the main lodge.

Please let me know.

Christopher T. Rembold, AICP
Town Planner
Town of Great Barrington
334 Main Street
Great Barrington, MA 01230
Ph: (413) 528-1619, x. 7
www.townofgb.org

Jennifer Bailly

From: Mark Pruhenski
Sent: Friday, June 13, 2014 12:21 PM
To: Chris Rembold
Cc: Charles Burger; Edwin May; Great Barrington Conservation Commission; Joseph Sokul; William Walsh; Jennifer Bailly
Subject: Re: Arts Market at Butternut

No issues with Health.....the food vendors are the same every year and they all know the drill. -m

Sent from my iPhone

On Jun 13, 2014, at 12:13 PM, "Chris Rembold" <crembold@Townofgb.org> wrote:

DRT,

Any issues with the annual Berkshire Arts Market at Ski Butternut? This year it will be July 4, 5, and 6. Includes artists and entertainment as usual in the lawns around the main lodge.

Please let me know.

Christopher T. Rembold, AICP
Town Planner
Town of Great Barrington
334 Main Street
Great Barrington, MA 01230
Ph: (413) 528-1619, x. 7
www.townofgb.org

Jennifer Bailly

From: William Walsh
Sent: Tuesday, June 17, 2014 1:48 PM
To: Jennifer Bailly
Subject: RE: Arts Market at Butternut

No issues

From: Jennifer Bailly
Sent: Tuesday, June 17, 2014 1:20 PM
To: Charles Burger; Edwin May; Great Barrington Conservation Commission; William Walsh
Cc: Helen Kuziemko
Subject: FW: Arts Market at Butternut
Importance: High

Hello!

I have not seen any emails back from you guys regarding the above entertainment event at Butternut. If you have replied back to Chris R. ONLY, can you please forward this response to Helen and I. Chris is on vacation this week and this is on the Selectboard's agenda for June 23. We need your responses back as soon as possible. Thank you!

Jenn

From: Chris Rembold
Sent: Friday, June 13, 2014 12:14 PM
To: Charles Burger; Chris Rembold; Edwin May; Great Barrington Conservation Commission; Joseph Sokul; Mark Pruhenski; William Walsh
Cc: Jennifer Bailly
Subject: Arts Market at Butternut

DRT,

Any issues with the annual Berkshire Arts Market at Ski Butternut? This year it will be July 4, 5, and 6. Includes artists and entertainment as usual in the lawns around the main lodge.

Please let me know.

Christopher T. Rembold, AICP
Town Planner
Town of Great Barrington
334 Main Street
Great Barrington, MA 01230
Ph: (413) 528-1619, x. 7
www.townofgb.org

Jennifer Bailly

From: Great Barrington Conservation Commission
Sent: Tuesday, June 17, 2014 3:46 PM
To: Chris Rembold
Cc: Jennifer Bailly; Helen Kuziemko
Subject: RE: Arts Market at Butternut

No Conservation Issues on this one.
-Shep

From: Chris Rembold
Sent: Friday, June 13, 2014 12:14 PM
To: Charles Burger; Chris Rembold; Edwin May; Great Barrington Conservation Commission; Joseph Sokul; Mark Pruhenski; William Walsh
Cc: Jennifer Bailly
Subject: Arts Market at Butternut

DRT,

Any issues with the annual Berkshire Arts Market at Ski Butternut? This year it will be July 4, 5, and 6. Includes artists and entertainment as usual in the lawns around the main lodge.

Please let me know.

Christopher T. Rembold, AICP
Town Planner
Town of Great Barrington
334 Main Street
Great Barrington, MA 01230
Ph: (413) 528-1619, x. 7
www.townofgb.org

Jennifer Bailly

From: Charles Burger
Sent: Tuesday, June 17, 2014 5:01 PM
To: Jennifer Bailly; Edwin May; Great Barrington Conservation Commission; William Walsh
Cc: Helen Kuziemko
Subject: RE: Arts Market at Butternut

No problems for the FD

Charles Burger
Chief, Great Barrington Fire Department
37 State Rd.
Great Barrington, MA 01230
Phone: 413-528-0788
Fax: 413-528-8315

From: Jennifer Bailly
Sent: Tuesday, June 17, 2014 1:20 PM
To: Charles Burger; Edwin May; Great Barrington Conservation Commission; William Walsh
Cc: Helen Kuziemko
Subject: FW: Arts Market at Butternut
Importance: High

Hello!

I have not seen any emails back from you guys regarding the above entertainment event at Butternut. If you have replied back to Chris R. ONLY, can you please forward this response to Helen and I. Chris is on vacation this week and this is on the Selectboard's agenda for June 23. We need your responses back as soon as possible. Thank you!

Jenn

From: Chris Rembold
Sent: Friday, June 13, 2014 12:14 PM
To: Charles Burger; Chris Rembold; Edwin May; Great Barrington Conservation Commission; Joseph Sokul; Mark Pruhenski; William Walsh
Cc: Jennifer Bailly
Subject: Arts Market at Butternut

DRT,

Any issues with the annual Berkshire Arts Market at Ski Butternut? This year it will be July 4, 5, and 6. Includes artists and entertainment as usual in the lawns around the main lodge.

Please let me know.

Christopher T. Rembold, AICP
Town Planner
Town of Great Barrington
334 Main Street
Great Barrington, MA 01230
Ph: (413) 528-1619, x. 7
www.townofgb.org

Jennifer Bailly

From: Edwin May
Sent: Wednesday, June 18, 2014 7:00 AM
To: Helen Kuziemko; Jennifer Bailly
Subject: FW: Arts Market at Butternut

From: Edwin May
Sent: Monday, June 16, 2014 7:15 AM
To: Chris Rembold
Subject: RE: Arts Market at Butternut

Tent and sign permits have been filed for and issued.

From: Chris Rembold
Sent: Friday, June 13, 2014 12:14 PM
To: Charles Burger; Chris Rembold; Edwin May; Great Barrington Conservation Commission; Joseph Sokul; Mark Pruhenski; William Walsh
Cc: Jennifer Bailly
Subject: Arts Market at Butternut

DRT,

Any issues with the annual Berkshire Arts Market at Ski Butternut? This year it will be July 4, 5, and 6. Includes artists and entertainment as usual in the lawns around the main lodge.

Please let me know.

Christopher T. Rembold, AICP
Town Planner
Town of Great Barrington
334 Main Street
Great Barrington, MA 01230
Ph: (413) 528-1619, x. 7
www.townofgb.org

FEE: \$25.00 x 16 = \$400.00

DATE: June 19, 2014



RECEIVED
TOWN MANAGER

JUN 19 2014

BOARD OF SELECTMEN
GREAT BARRINGTON, MA

TOWN OF GREAT BARRINGTON

APPLICATION FOR ONE DAY LIQUOR LICENSE

TO THE LICENSING AUTHORITY:

The undersigned hereby applies for a License in accordance with the provisions relating thereto:

APPLICANT'S NAME: Ilan Bachrach

ORGANIZATION NAME: Mass Live Arts, Inc

APPLICANT'S ADDRESS: 22 Old Village Rd., Alford MA 01230

Type of license being Applied for: ONE DAY BEER & WINE ONE DAY ALL ALCOHOLIC

EVENT: Mass Live Arts

DATE: see attached START TIME: see attached END TIME: see attached

LOCATION: Daniel Arts Center, Bard College at Simons Rock
84 Alford Road Great Barrington, 01230

EVENT ON TOWN PROPERTY? Yes _____ No X

IF YES, PLEASE ATTACH CERTIFICATE OF LIQUOR LIABILITY INSURANCE.

In accordance with the rules and regulations made under authority of said Statutes.

Signature of Applicant

22 Old Village Road, Alford MA 01230

Mailing Address

617-877-3407

Telephone Number

Decision:

Approved _____

Denied _____

Postponed _____

* TIPS Cert. attached.

Town of Great Barrington

Application For One Day Liquor License

Mass Live Arts is applying for 16 one day beer & wine permits for the follow days and hours.

1	July 07	6pm - 12am
2	July 08	6pm - 12am
3	July 10	6pm - 12am
4	July 11	6pm - 12am
5	July 12	6pm - 12am
6	July 14	6pm - 12am
7	July 15	6pm - 12am
8	July 16	6pm - 12am
9	July 17	6pm - 12am
10	July 18	6pm - 12am
11	July 20	6pm - 12am
12	July 21	6pm - 12am
13	July 22	6pm - 12am
14	July 24	6pm - 12am
15	July 25	6pm - 12am
16	July 26	6pm - 12am

Beer and Wine Service Plan

1. Maurina Lioce, festival producer, is TIPS certified, in both Massachusetts (see attached) and in New York State.
2. In addition to Maurina Lioce, all five (5) inters and (2) front of house employees are over 21 years old and will participate in TIPS certification within the first day of their arrival at MLA on July 2nd.
3. All beer and wine distribution and consumption will occur in a specially designated area under the tent, located in the Lawn Court (see site plan below)
4. Tent is being provided by Classical Tents and measures 20" x 30"
5. At all times during service there will be two (2) tips certified servers on duty in the tent as well as one (1) tips certified bar manager to oversee the service.

Site Plan

Daniel Arts Center, Simon's Rock

Red rectangle indicates location where designated tent will be located.

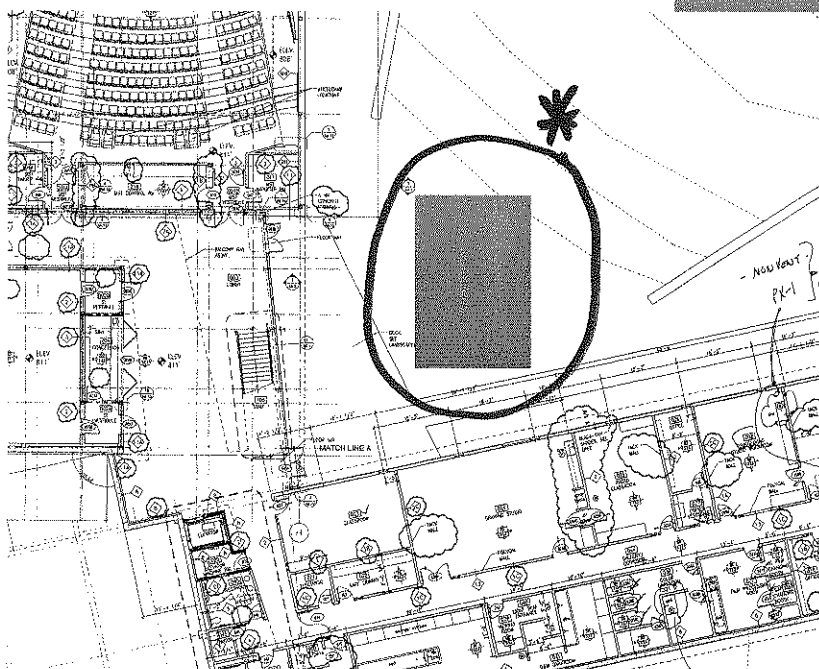
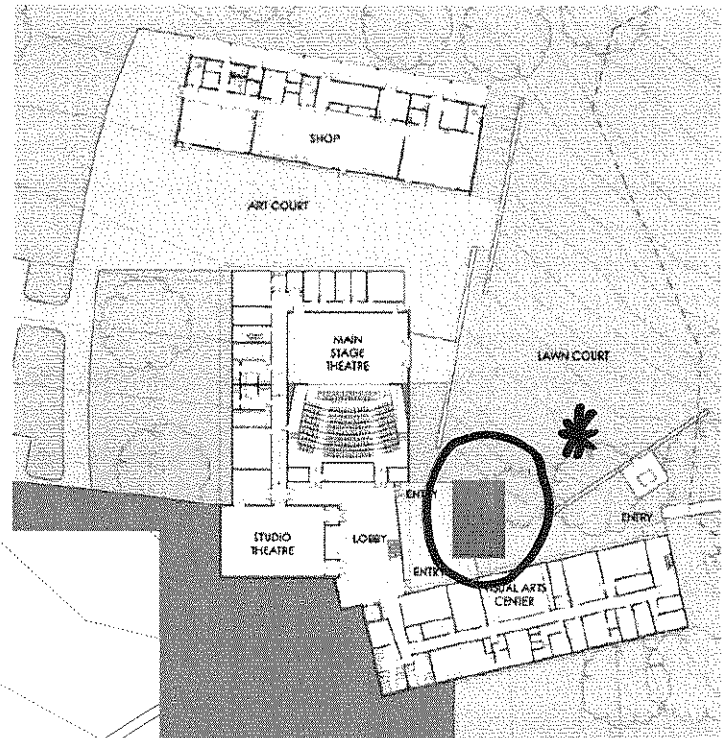



RECEIVED
TOWN MANAGER

JUN 20 2014

BOARD OF SELECTMEN
GREAT BARRINGTON, MA

Ilan Bachrach
Mass Live Arts
P.O. Box 322
Great Barrington, MA 01230

June 19, 2014

Dear Mr. Bachrach:

On behalf of Bard College at Simon's Rock I am thrilled to be welcoming the Mass Live Arts festival back to the Daniel Arts Center this July. We're so happy for the success of your inaugural season last summer and look forward to our ongoing relationship as one of your sponsors.

We, once again, grant your organization permission to serve beer and wine under your tent on the back lawn of the Arts Center outside of the lower lobby.

With best wishes for a successful summer,

Sandy Cleary-Wade

A handwritten signature in cursive script that reads "Sandy Cleary-Wade". The signature is written in dark ink and is positioned above the typed name.

Director of the Daniel Arts Center
Bard College at Simon's Rock

Certificate of Completion

This Certificate of Completion of
eTIPS On Premise 2.0
For coursework completed on May 26, 2014
provided by Health Communications, Inc.
is hereby granted to:

Maurina Lioce

Certification to be sent to:

22 Old Village Rd
Great Barrington MA, 01230-8900 USA



HEALTH COMMUNICATIONS, INC.

This document is not part of TIPS certification. It signifies only that you have completed the course. Valid certification documents will be forwarded to you.

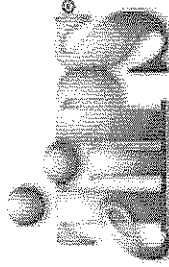

*Expires
5/26/17*

FEE: \$25.00

DATE: 6.16.14



TOWN OF GREAT BARRINGTON

APPLICATION FOR ONE DAY LIQUOR LICENSE

TO THE LICENSING AUTHORITY:

The undersigned hereby applies for a License in accordance with the provisions relating thereto:

APPLICANT'S NAME: Cathy Ingram

ORGANIZATION NAME: Bard College at Simon's Rock

APPLICANT'S ADDRESS: 84 Alford Rd

Type of license being Applied for:

ONE DAY BEER & WINE

ONE DAY ALL ALCOHOLIC

EVENT: Reunion

DATE: Sat. July 12, 2014 START TIME: 3 pm END TIME: 9 pm

LOCATION: Dining Hall + Tri-dorm lawn @ Bard College @ Simon's Rock Campus

EVENT ON TOWN PROPERTY? Yes _____ No

IF YES, PLEASE ATTACH CERTIFICATE OF LIQUOR LIABILITY INSURANCE.

In accordance with the rules and regulations made under authority of said Statutes.

Cathy Ingram
Signature of Applicant

84 Alford Rd. Great Barrington, MA 01230
Mailing Address

413-528-7266
Telephone Number

Decision: Approved _____ Denied _____ Postponed _____

* TIPS Cert. Attached.
* Cert. of Liquor Liability Attached.

Simon's Rock Reunion
Rockfest BBQ
event layout:

Saturday, June 1st

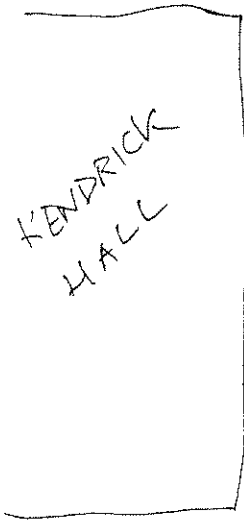
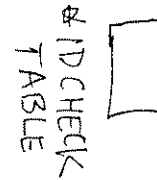
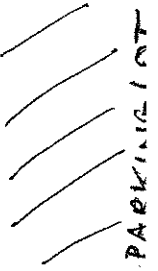
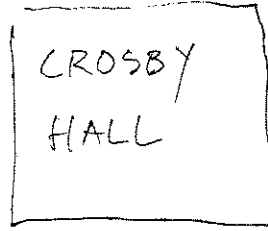

TABLES
& CHAIRS
for
SEATING
AREA

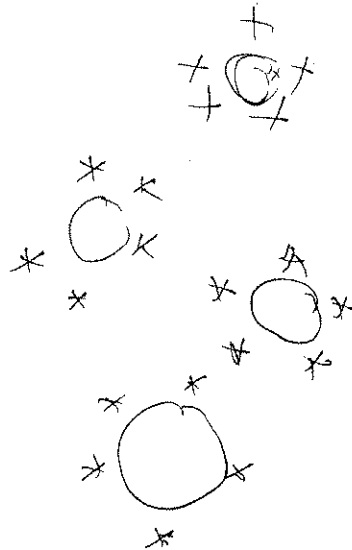

CASH BAR

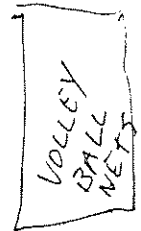
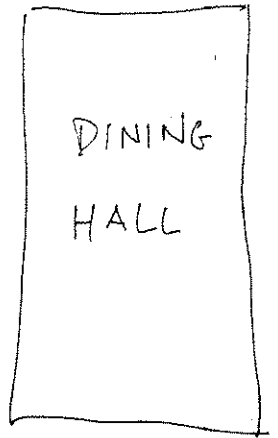

* EVENT IN DINING HALL, in case of inclement weather.

Print Close Window

Certificate of Completion

This Certificate of Completion of
eTIPS On Premise 2.0
For coursework completed on June 19, 2014
provided by Health Communications, Inc.
is hereby granted to:

Selena van Lingen

Certification to be sent to:

**Bard College at Simon's Rock
84 Alford Rd
Great Barrington MA, 01230-1978 USA**



HEALTH COMMUNICATIONS, INC.

This document is not proof of TIPS certification. It certifies only that you have completed the course. Valid certification documents will be forwarded to you.

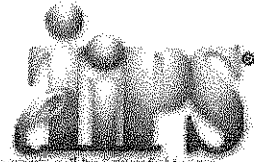

WEEKEND OVERVIEW

FRIDAY

WELCOME RECEPTION AT BLODGETT HOUSE

Meet your friends and make plans for the rest of the weekend. Enjoy the comfort and beauty of Blodgett House inside and out.



SATURDAY

ALUMNI COLLEGE

Sit in class as a student again and experience the Simon's Rock of today with Rockers of all ages. During these 90-minute seminar-style classes, current and former faculty from various disciplines will lead discussions in a range of topics.



ROCKFEST

Remember the outdoor picnics and MayFest? Come enjoy music, food and games for all on Kendrick Lawn.



ALUMNI COFFEEHOUSE AND BONFIRE

Enjoy performances by fellow Rockers in this laid-back setting. Want to entertain? Bring your instrument and join in the fun. Afterwards, gather 'round the fire with old and new friends and enjoy the impromptu fun of it all.



SUNDAY

JAZZ BRUNCH

Witness the 2014 Outstanding Alumni Awards. Help honor the anniversary classes and say farewell to friends for the weekend.



DEAR ROCKERS,

Spring has finally arrived in the Berkshires! With the warmer weather ahead, we hope you will include the Simon's Rock Reunion in your summer plans.

Join us for a beautiful summer weekend in the Berkshires for a memorable time with old friends, classmates, faculty and staff. Want to see your old roommate or the friends you studied with in the Alumni Library? Give them a call and make plans to come back to Simon's Rock.

The Reunion Committee has put together a weekend of activities for everyone. Enjoy sunset from Blodgett porch, attend a class, share music and hang with pals on Kendrick Lawn, workout at the Kilpatrick Athletic Center, catch a show at the Daniel Arts Center, or just be with friends at your favorite spot on campus.

Show your pride during Reunion weekend by sporting your favorite Simon's Rock gear, and don't forget to wear your Sapling Society pin. Summer is just around the corner, so get your friends and family ready to come back to Simon's Rock.

We look forward to seeing you!

REUNION COMMITTEE

Peggy Clark '80
Meriweather Clark-Connor's '76

David Collins '99
Cordelia Derhammer-Hill '86

Valerie Ferrier '94



THE DETAILS

Keep up with the latest reunion information at simons-rock.edu/reunion. You can check out the full schedule and see the list of classmates who are planning to attend. Also, join the chatter on the Reunion 2014 event page at facebook.com/simonsrockalumni.

REGISTRATION

Register online at simons-rock.edu/reunion. Advance registration is required by June 27th. A printable registration form is also available at simons-rock.edu/reunion.

STAYING ON CAMPUS

Want to stay on campus for Reunion? Rooms will be available in Crosby and Kendrick. Please remember that dorm accommodations are basic. Most rooms have two single beds. A pillow, blanket and sheets are provided for each bed.

The room fee is \$95 per adult for the weekend. There is no charge for children, but they must stay in the same room as the parent. There is a \$20 refundable cash room key deposit required at the time of check-in.

STAYING AT A LOCAL HOTEL

If you prefer to stay off-campus, we recommend that you make reservations early. The summer months are a popular time in the Berkshires!

You can find current information about local accommodations at the Berkshires Visitors Bureau and the Southern Berkshire Chamber of Commerce web sites: berkshires.org or southernberkshirechamber.com

GUESTS

You are welcome to bring a friend, partner, spouse, and/or your children. There is no registration fee for children and there is a reduced rate for children under 12 at meals. Children are welcome to join you at all Reunion activities and must be supervised at all times on campus.

ATM ON CAMPUS

Please be sure to bring extra cash with you for the weekend. Some events feature cash bars, and both food and beverages will be sold during the Alumni Coffeehouse. There is an ATM located in the Student Union for your convenience.

KILPATRICK ATHLETIC CENTER

The Kilpatrick Athletic Center will be open throughout the weekend. Alumni and their registered guests are welcome to use the facilities at no charge.

QUESTIONS?

Check out the reunion web page for more info: simons-rock.edu/reunion or Please contact Cathy Ingram, Alumni & Parent Relations Officer, at (413) 528-7266 or c Ingram@simons-rock.edu

Kindred Gr8t Road Race - Agenda Item #6F

Jennifer Bailly

From: John Krol <john@oneeightymedia.com>
Sent: Monday, June 09, 2014 1:27 PM
To: Jennifer Bailly
Subject: Gr8t Road Race-Aug 16

Hi Jenn,

Thank you again for all your help in making our inaugural Gr8t Road Race a nice success last year, which was a nice foundation to build from for a greater success this year and beyond.

This year, we're planning on having the race on Saturday, Aug 16 - same time, same course, etc.

Please let me know what I can do to make sure we get the proper approvals again for this year's race.

Below is a description of the race (start time, course, etc.).

Thank you so much,

John Krol

413-464-5830

The Kindred Gr8t Road Race will take place Saturday August 16, 2014. Start time for the race is 8 AM. Day of race registration and number pick up will be from 6:30-7:30 AM at the Kindred Facility located at 148 Maple Ave., Gt. Barrington, MA. The race start will be near the Newsboy Statue on Silver St. and the finish will be near the Kindred Facility on Maple Ave. This 8 mile road race will go West on Maple Ave. (RT.23) and turn left onto West Sheffield road, following that and turning left onto Lime Kiln Road. A quick right and left turn across Rt. 7 in Sheffield will put you onto Kellogg St., a left onto Boardman St. which turns into East Sheffield Rd., left onto Brookside Rd., right onto S. Main St. (RT 7N), left onto Pope Street and another left onto Maple Ave. (RT. 23) to the finish near the Kindred Facility.

RECEIVED
TOWN MANAGER

JUN 10 2014

BOARD OF SELECTMEN
GREAT BARRINGTON, MA

Current Membership #

Log In

Don't know your current membership number or password?

Join/Rejoin Now



USATF STORE

P

Kindred GR8T

Distance: 8.00 miles / 12.88 km
Location: Start: Newsboy
 Great Barrington, MA, US
Attributes: loop, mostly flat, roads

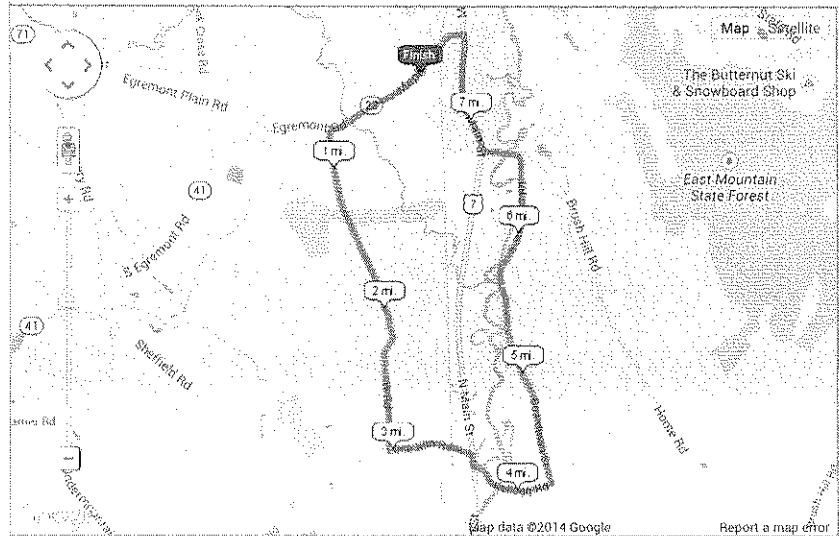

Elevation Profile

Click to view elevation profile

0

Total climb: 0 feet / 0 m

Total elevation change: 0 feet / 0 m

Added by Kent Lemme on 6/10/2013

DISCLAIMER: USATF and the author of this route make no warranties as to the conditions, safety, distance accuracy, or suitability for running of this route. Run at your own risk!



University of Phoenix



St. Vincent Sports Performance



About

- Associations
- Bylaws & Regulations
- Employment & Internships
- Organizational Directory
- Annual Report
- Event Sanctions
- Memberships
- Course Certification

News

- Athlete Bios
- Stats
- Records
- Top-Marks Lists
- Committees
- Hall of Fame

Sports

- Track & Field
- Cross Country
- Road Running
- Race Walking
- Mountain / Ultra / Trail

Groups

- Youth Athletes
- Masters Athletes
- Elite Athletes
- Athlete Alumni
- Coaches
- Officials
- Athlete Representatives
- Event Directors
- Media

Events

- Search the Calendar
- Team USA Events
- National Championships
- USA Running Circuit
- USATF Championship Series
- Television Schedule
- USATF Annual Meeting

Customer Service

- Log In
- Individual Memberships
- Club Memberships
- Store Returns & Exchanges
- Store Affiliate Program
- Contact Us
- Privacy & Other Policies

* DRT review *

Jennifer Bailly

From: Chris Rembold
Sent: Wednesday, June 18, 2014 3:43 PM
To: Jennifer Bailly
Subject: RE: Gr8t Road Race-Aug 16

Yes, all DRT staff have reviewed the proposal. We have no issues. It is the same as last year.

However, we note that runners will be coming north on Route 7 near the Fairgrounds just about the time that the Farmer's Market is opening that morning. The Applicants expect that the runners to be clear of the area around 9:00 or so, by the time Farmer's Market traffic really starts to ramp up, so we think this situation should be okay.

Chris

Christopher Rembold, AICP
Town Planner
Town of Great Barrington
(413) 528-1619, ext. 7

From: Jennifer Bailly
Sent: Wednesday, June 18, 2014 10:47 AM
To: Chris Rembold
Subject: RE: Gr8t Road Race-Aug 16

Chris,

Has the DRT been able to review this? If not, I will let John know it has to be on the July 14 agenda.

Jenn



TOWN OF GREAT BARRINGTON
MASSACHUSETTS

DEPARTMENT OF PUBLIC WORKS

EXECUTIVE SUMMARY

TITLE: Petition – Verizon Job #1A0M5VQ – Main Street

BACKGROUND: Verizon has filed a petition and requests permission to lay and maintain underground conduits and manholes with wires and cables. The following work is included in the petition; replace manhole on the westerly side of Main Street at the intersection of Main Street and Elm Street, replace manhole on the westerly side of Main Street at the intersection of Main and Dresser Avenue, install two (2) four (4) inch conduits between manholes.

The proposed work is in accordance with the proposed MassDOT Main Street Reconstruction Project.

The petitioner agrees that all associated equipment being installed or updated meet or exceed the latest version of the National Electrical Safety Code (NESC) as of the date of this petition.

The Department of Public Works has reviewed this location in the field and has no issues with the proposed work.

FISCAL IMPACT: There is no fiscal impact for the Town.

RECOMMENDATION: The Board of Selectmen approves the petition as submitted.

PREPARED AND REVIEWED BY:

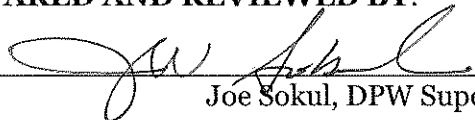

Joe Sokul, DPW Superintendent

DATE: 06/02/2014

APPROVED:



Jennifer Tabakin, Town Manager

DATE: 6/4/14

Albert E. Bessette
Right of Way Manager

RECEIVED
TOWN MANAGER

MAY 19 2014

BOARD OF SELECTMEN
GREAT BARRINGTON, MA



365 State Street
Springfield, MA 01105

Phone 413 787-0310
Cell 413 441-3612
Fax 413 734-9123
albert.e.Bessette.jr@verizon.com

May 16, 2014

Great Barrington Board of Selectmen
Town Hall
334 Main Street
Great Barrington, MA 01230

**RE: Petition for Verizon job #1A0M5VQ
Main Street**

Dear Honorable Board of Selectmen:

Enclosed find the following items in support of the above-referenced project:

1. Petition;
2. Petition Plan;
3. Order;
4. Abutter Notice Cards.

A Public hearing and notice to abutters is required. A Verizon representative will attend the Public hearing. Should any questions or comments arise concerning this matter prior to the hearing, please contact me at (413) 787-0310. Your Assistance is greatly appreciated.

Sincerely,

A handwritten signature in black ink, appearing to read "Albert E. Bessette, Jr.", with a large, sweeping flourish extending to the right.

Albert E. Bessette, Jr.
Right of Way Manager

Enc

PETITION FOR MANHOLE AND CONDUIT LOCATIONS

Springfield, Massachusetts, dated May 16, 2014

To the Board of Selectmen of the Town of Great Barrington, Massachusetts

VERIZON NEW ENGLAND, INC. requests permission to lay and maintain underground conduits and manholes, with the wires and cables to be placed therein, under the surface of the following public way or ways:

MAIN STREET: Replace Manhole 5, located on the Westerly side of Main Street at the intersection of Main Street and Elm Street, from a 5'x3.6'x3.6 structure to a 10'x5'x7' structure.

MAIN STREET: Replace Manhole 6, located on the Westerly side of Main Street at the intersection of Main Street and Dresser Avenue, from a 5'x3.6'x3.6 structure to a 10'x5'x7' structure.

MAIN STREET: Place two (2) four (4) inch conduits on Main Street beginning at Manhole 5, located on the Westerly side of Main Street at the intersection of Main Street and Elm Street, and then running in a Northeasterly direction a distance of approximately fifty-six (56) feet to Manhole 5A, located on the Easterly side of Main Street.

Reason: Place conduit and replace two manholes on Main Street in accordance with a Massachusetts Department of Transportation road construction project; and to provide for the distribution of intelligence and telecommunications.

Also for permission to lay and maintain underground conduits, manholes, cables and wires in the above or intersecting public ways for the purpose of making connections with such poles and buildings as it may desire for distributing purposes.

Plans marked - Verizon No. 1A0M5VQ, dated May 13, 2014, showing location of conduit to be constructed is filed herewith.

VERIZON NEW ENGLAND, INC.

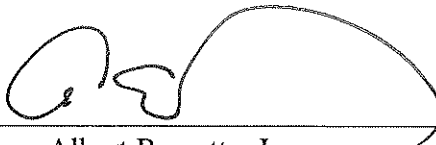
By 
Albert Bessette, Jr.
Manager-Right of Way



PETITION PLAN

MUNICIPALITY GREAT BARRINGTON

NO. 1A0M5VQ

VERIZON NEW ENGLAND, INC.

DATE: 5/13/2014

SHOWING PROPOSED CONDUIT AND MANHOLE ON MAIN STREET

Plan 1 of 2

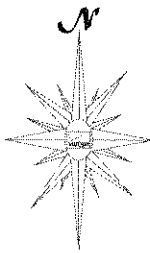

Parcel Id
113/014.0-0000-0217.0

Place 56' of
2-4" Conduit
(concrete encased)

Old MH5 = 5'x3.6'x3.6'
New MH5 = 10'x5'x7'

Existing
Manhole 5
To be Replaced

Elm Street

Main Street

90'

Pleasant Street

Parcel Id
113/019.0-0000-0101.0

Existing
MH 5A

56'

TRENCH DETAILS

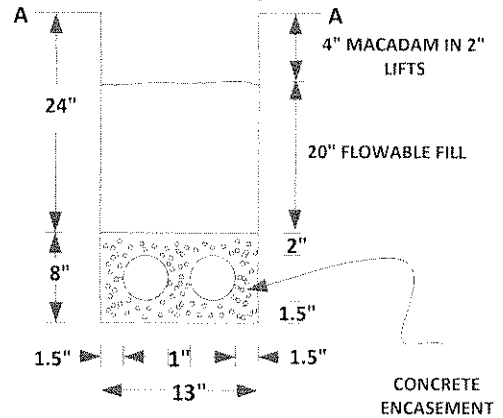

PROPOSED VERIZON POLE



VERIZON POLE TO BE REMOVED



VERIZON POLE TO REMAIN



PROPOSED JOINTLY OWNED POLE



EXISTING VERIZON MANHOLE



EXISTING VERIZON CONDUIT

LEGEND



EXISTING JOINTLY OWNED POLE TO REMAIN



POWER CO. POLE TO BE REMOVED



EXISTING JOINTLY OWNED POLE TO BE REMOVED



EXISTING POWER CO. POLE TO BE HELD JOINTLY

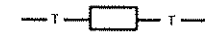

PROPOSED VERIZON MANHOLE



PROPOSED VERIZON CONDUIT



PROPOSED VERIZON CABINET



PETITION PLAN

MUNICIPALITY GREAT BARRINGTON

NO. 1A0M5VQ

VERIZON NEW ENGLAND, INC.

DATE: 5/13/2014

SHOWING PROPOSED MANHOLE ON MAIN STREET

Plan 2 of 2

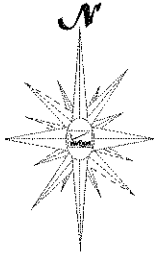

Parcel Id
113/014.0-0000.0202.0

Existing
Manhole 6
To be Replaced

Paved Alley

Old MH6 = 5'x3.6'x3.6'
New MH6 = 10'x5'x7'

Parcel Id
113/014.0-0000-0204.0

Main Street

Parcel Id
113/014.0-0000-228.0

Dresser Avenue

Parcel Id
113/014.0-0000-0237.0



PROPOSED VERIZON POLE



VERIZON POLE TO BE REMOVED



VERIZON POLE TO REMAIN



PROPOSED JOINTLY OWNED POLE



EXISTING VERIZON MANHOLE

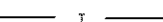

EXISTING VERIZON CONDUIT

LEGEND



EXISTING JOINTLY OWNED POLE TO REMAIN



POWER CO. POLE TO BE REMOVED



EXISTING JOINTLY OWNED POLE TO BE REMOVED



EXISTING POWER CO. POLE TO BE HELD JOINTLY

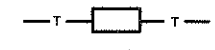

PROPOSED VERIZON MANHOLE

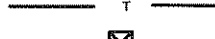

PROPOSED VERIZON CONDUIT



PROPOSED VERIZON CABINET

NOTICE TO ABUTTERS

In accordance with the provisions of Section 22, Chapter 166, of the Massachusetts General Laws, you are hereby notified that a public hearing will be held at Town Hall, 334 Main Street in the town/city of Great Barrington, Mass at 7:00 P.M. on the petition 1AØM5VQ of VERIZON NEW ENGLAND INC. date of hearing June 23, 2014

to place underground conduit and manholes

on Main Street in Great Barrington abutting upon property owned by you.

For information concerning this petition call Al Bessette RW Manager, Verizon New England @ 413- 787-Ø31Ø

Town/City Clerk

Marie y Ryan, cnc

VERIZON
Right of Way
365 State Street
Springfield, MA 01105



VERIZON
Right of Way
365 State Street
Springfield, MA 01105



Society of Congregational Church
PO Box 660
Great Barrington, MA 01230-0660

Ried Realty Corporation
C/O Cathy Coffman
218 Main Street
Great Barrington, MA 01230-1215

VERIZON
Right of Way
365 State Street
Springfield, MA 01105



Mailed
6/3/14

Roman Catholic Bishop of Springfield
PO Box 1730
Springfield, MA 01103-1730

VERIZON
Right of Way
365 State Street
Springfield, MA 01105



VERIZON
Right of Way
365 State Street
Springfield, MA 01105

Berkshire Bank
C/O Peter Merwin
244 Main Street
Great Barrington, MA 01201-5106

Albert Bessette, Jr.
Right of Way Manager
Verizon New England, Inc.
365 State Street
Springfield, MA 01105

VERIZON
Right of Way
365 State Street
Springfield, MA 01105



VERIZON
Right of Way
365 State Street
Springfield, MA 01105

United States Post Office
222 Main Street
Great Barrington, MA 01230-1601

Town of Great Barrington
Mason Library
334 Main Street
Great Barrington, MA 01230-1832



DEBORAH PHILLIPS
CHAIR

SEAN A. STANTON
STEPHEN C. BANNON
DANIEL BAILLY
EDWARD ABRAHAMS



Town Hall, 334 Main Street
Great Barrington, MA 01230

Telephone: (413) 528-1619 x2
Fax: (413) 528-2290
website: www.townofgb.org

TOWN OF GREAT BARRINGTON MASSACHUSETTS

SELECTBOARD

CONSENT TO TRANSFER OF CONTROL RESOLUTION

WHEREAS, Time Warner Cable Northeast LLC ("Franchisee") is the duly authorized holder of a franchise, as amended to date (the "Franchise"), authorizing Franchisee to serve the Town of Great Barrington, MA (the "Franchise Authority") and to operate and maintain a cable television system therein (the "System"); and

WHEREAS, Time Warner Cable Inc. ("Time Warner Cable") is the ultimate parent company of Franchisee; and

WHEREAS, on February 12, 2014, Time Warner Cable, Comcast Corporation ("Comcast") and Tango Acquisition Sub, Inc. ("Tango"), entered into an Agreement and Plan of Merger (the "Agreement"), pursuant to which Time Warner Cable will merge with Tango, a wholly-owned subsidiary of Comcast, with Time Warner Cable as the surviving company, and Time Warner Cable will thereby become a wholly-owned subsidiary of Comcast (the "Transaction"); and

WHEREAS, Franchisee now seeks approval of the Transaction and has filed an FCC Form 394 with the Franchise Authority with respect thereto; and

WHEREAS, the Franchise Authority has considered and approves of the Transaction.

NOW, THEREFORE, BE IT RESOLVED BY THE FRANCHISE AUTHORITY AS FOLLOWS:

1. The foregoing recitals are approved and incorporated herein by reference.
2. The Franchise Authority consents to the Transaction.
3. The Franchise Authority confirms that the Franchise is valid and outstanding and in full force and effect and there are no defaults under the Franchise. Subject to compliance with the terms of this Resolution, all action necessary to approve the transfer of control of the Franchisee to Comcast has been duly and validly taken.

4. Comcast or the Franchisee may (a) assign or transfer its assets, including the Franchise, provided that such assignment or transfer is to an entity directly or indirectly controlling, controlled by or under common control with Comcast; (b) restructure debt or change the ownership interests among existing equity participants in Comcast; (c) pledge or grant a security interest to any lender(s) of Comcast's assets, including, but not limited to, the Franchise, or of interest in Comcast, for purposes of securing any indebtedness; and (d) sell equity interests in Comcast or any of Comcast's affiliates.

5. Upon closing of the Transaction, the Franchisee shall remain bound by the lawful terms and conditions of the Franchise.

6. This Resolution shall be deemed effective upon adoption.

7. This Resolution shall have the force of a continuing agreement with the Franchisee, and the Franchise Authority shall not amend or otherwise alter this Resolution without the consent of the Franchisee and Comcast.

PASSED, ADOPTED AND APPROVED this 23rd day of July, 2014.

Great Barrington Selectboard

ATTEST:

Town Clerk



One Comcast Center
Philadelphia, Pennsylvania 19103

April 9, 2014

RECEIVED
TOWN MANAGER

APR 10 2014

BOARD OF SELECTMEN
GREAT BARRINGTON, MA

Sean Stanton
Chairman
Town of Great Barrington
334 Main Street
Great Barrington, MA 01230

Re: Time Warner Cable/Comcast Corporation Transaction

Dear Mr. Stanton:

As you may have read, Time Warner Cable Inc. ("Time Warner Cable") has entered into an agreement to become a wholly-owned subsidiary of Comcast Corporation ("Comcast"). Upon conclusion of the transaction, your local Franchisee (currently an indirect subsidiary of Time Warner Cable) will remain in place but will be ultimately owned by Comcast.

Attached are charts to assist you in understanding how the transaction will be completed. Time Warner Cable will merge with Tango Acquisition Sub, Inc., a wholly-owned subsidiary of Comcast, with Time Warner Cable as the surviving company. Time Warner Cable will thereby become a wholly-owned subsidiary of Comcast.

If you determine that your consent is **not** required for this transaction to proceed, you need not take any further action. If, however, you believe your consent is necessary, we have provided copies of the Federal Communications Commission's ("FCC") Form 394, other information, and a draft consent resolution to help facilitate the consent process.

- **FCC Form 394.** FCC Form 394 (required copies enclosed) is designed to provide you with the relevant information needed to assess the financial, legal, and technical qualifications of Comcast to be the ultimate parent entity of your Franchisee.
- **Timing.** According to the FCC's rules, you have a maximum of 120 days from the date you receive this information to review all materials and act upon our request for consent to the transaction. (Please note, your franchise may specify a shorter time frame.)
- **Consent Resolution.** Should you choose to affirmatively consent to the transaction, we have enclosed a draft consent resolution to be used to help expedite the consent process. We would request that a consent resolution, if needed, be placed on your agenda for consideration at your earliest convenience.

All of us at Comcast are excited about the opportunity to serve your community. We invite you to visit www.comcastcorporation.com/together for additional information about the transaction and Comcast. If you have any questions about the FCC Form 394, the consent resolution, or any of the enclosed documents, please give me a call at (215) 286-5585, send an email to klay_fennell@comcast.com, or send a facsimile to (215) 286-8408.

Sincerely,

Klayton F. Fennell
Vice President, Government Affairs
Attachment and Enclosures

TWC 394 Structure Before Merger

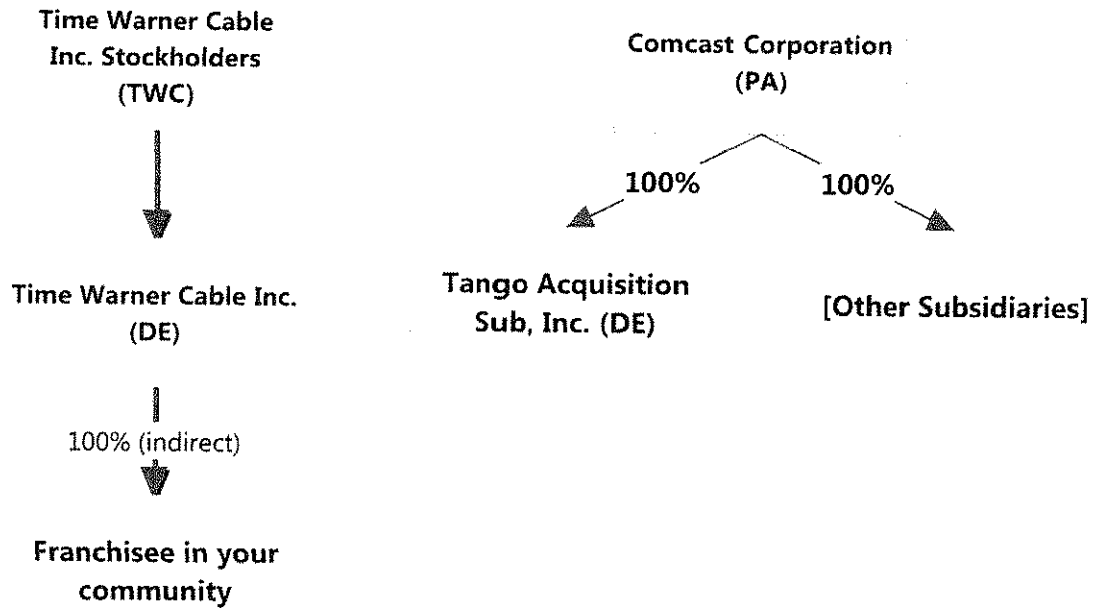

TWC 394 Structure After Merger

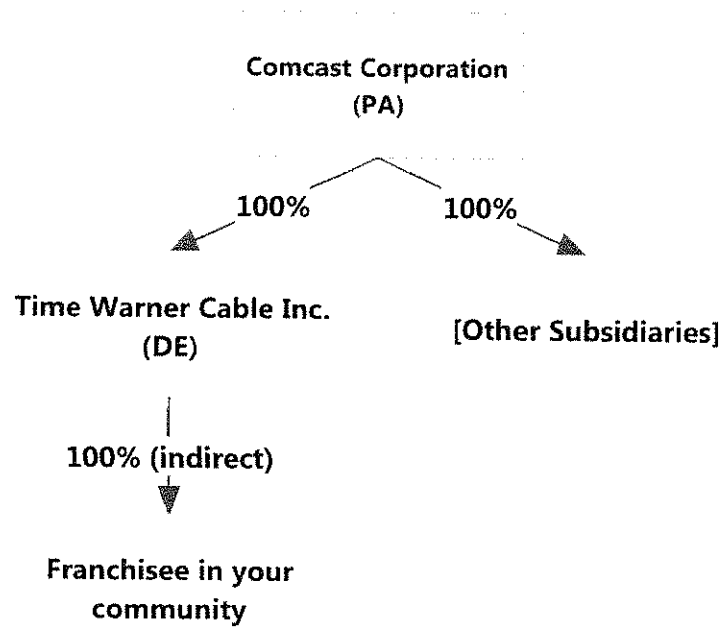

PART II - TRANSFEREE/ASSIGNEE

1. (a) Indicate the name, mailing address, and telephone number of the transferee/assignee.

Legal name of Transferee/Assignee (if individual, list last name first) Comcast Corporation			
Assumed name used for doing business (if any) Comcast			
Mailing street address or P.O. Box One Comcast Center			
City Philadelphia	State PA	ZIP Code 19103	Telephone No. (include area code) 215-286-1700

(b) Indicate the name, mailing address, and telephone number of person to contact, if other than transferee/assignee.

Name of contact person (list last name first) Klayton F. Fennell (klay_fennell@comcast.com)			
Firm or company name (if any) Comcast Cable Communications, LLC			
Mailing street address or P.O. Box One Comcast Center			
City Philadelphia	State PA	ZIP Code 19103	Telephone No. (include area code) 215 286-5585 (voice) 215-286-8408 (fax)

(c) Attach as an Exhibit the name, mailing address, and telephone number of each additional person who should be contacted, if any.

Exhibit No. N/A

(d) Indicate the address where the system's records will be maintained.

Street address One Comcast Center (or a regional or area office as appropriate)		
City Philadelphia	State PA	ZIP Code 19103

2. Indicate on an attached exhibit any plans to change the current terms and conditions of service and operations of the system as a consequence of the transaction for which approval is sought.

Exhibit No. 2

SECTION II. TRANSFEREE'S/ASSIGNEE'S LEGAL QUALIFICATIONS

1. Transferee/Assignee is:

Corporation

a. Jurisdiction of incorporation: Pennsylvania	d. Name and address of registered agent in jurisdiction: CT Corporation System 2001 Market Street Philadelphia, PA 19103
b. Date of incorporation: December 7, 2001	
c. For profit or not-for-profit: For profit	

Limited Partnership

a. Jurisdiction in which formed:	c. Name and address of registered agent in jurisdiction:
b. Date of formation:	

General Partnership

a. Jurisdiction whose laws govern formation:	b. Date of formation:
----------------------------------------------	-----------------------

Individual

Other. Describe in an Exhibit.

Exhibit No. N/A

2. List the transferee/assignee, and, if the transferee/assignee is not a natural person, each of its officers, directors, stockholders beneficially holding more than 5% of the outstanding voting shares, general partners, and limited partners holding an equity interest of more than 5%. Use only one column for each individual or entity. Attach additional pages if necessary. (Read carefully- the lettered items below refer to corresponding lines in the following table.)

- (a) Name, residence, occupation or principal business, and principal place of business. (If other than an individual, also show name, address and citizenship of natural person authorized to vote the voting securities of the applicant that it holds.) List the applicant first, officers, next, then directors and, thereafter, remaining stockholders and/or partners.
- (b) Citizenship.
- (c) Relationship to the transferee/assignee (e.g., officer, director, etc.).
- (d) Number of shares or nature of partnership interest.
- (e) Number of votes.
- (f) Percentage of votes.

(a)	See Exhibit 3	
(b)		
(c)		
(d)		
(e)		
(f)		

3. If the applicant is a corporation or a limited partnership, is the transferee/assignee formed under the laws of, or duly qualified to transact business in, the State or other jurisdiction in which the system operates?

Yes No

If the answer is No, explain in an Exhibit.

Exhibit No. 4

4. Has the transferee/assignee had any interest in or in connection with an applicant which has been dismissed or denied by any franchise authority?

Yes No

If the answer if Yes, describe circumstances in an Exhibit.

Exhibit No. 5

5. Has an adverse finding been made or an adverse final action been taken by any court or administrative body with respect to the transferee/assignee in a civil, criminal or administrative proceeding, brought under the provisions of any law or regulation related to the following: any felony; revocation, suspension or involuntary transfer of any authorization (including cable franchises) to provide video programming services; mass media related antitrust or unfair competition; fraudulent statements to another government unit; or employment discrimination?

Yes No

If the answer is Yes, attach as an Exhibit a full description of the persons and matter(s) involved, including an identification of any court or administrative body and any proceeding (by dates and file numbers, if applicable), and the disposition of such proceeding.

Exhibit No. N/A

6. Are there any documents, instruments, contracts or understandings relating to ownership or future ownership rights with respect to any attributable interest as described in Question 2 (including, but not limited to, non-voting stock interests, beneficial stock ownership interests, options, warrants, debentures)?

Yes No

If Yes, provide particulars in an Exhibit.

7. Do documents, instruments, agreements or understandings for the pledge of stock of the transferee/assignee, as security for loans or contractual performance, provide that: (a) voting rights will remain with the applicant, even in the event of default on the obligation; (b) in the event of default, there will be either a private or public sale of the stock; and (c) prior to the exercise of any ownership rights by a purchaser at a sale described in (b), any prior consent of the FCC and/or of the franchising authority, if required pursuant to federal, state or local law or pursuant to the terms of the franchise agreement will be obtained?

Yes No

N/A

If No, attach as an Exhibit a full explanation.

Exhibit No. N/A

SECTION III. TRANSFEREE'S/ASSIGNEE'S FINANCIAL QUALIFICATIONS

1. The transferee/assignee certifies that it has sufficient net liquid assets on hand or available from committed resources to consummate the transaction and operate the facilities for three months.

Yes No

2. Attach as an Exhibit the most recent financial statements, prepared in accordance with generally accepted accounting principles, including a balance sheet and income statement for at least one full year, for the transferee/assignee or parent entity that has been prepared in the ordinary course of business, if any such financial statements are routinely prepared. Such statements, if not otherwise publicly available, may be marked CONFIDENTIAL and will be maintained as confidential by the franchise authority and its agents to the extent permissible under local law.

Exhibit No. 6

SECTION IV. TRANSFEREE'S/ASSIGNEE'S TECHNICAL QUALIFICATIONS

Set forth in an Exhibit a narrative account of the transferee's/assignee's technical qualifications, experience and expertise regarding cable television systems, including, but not limited to, summary information about appropriate management personnel that will be involved in the system's management and operations. The transferee/assignee may, but need not, list a representative sample of cable system currently or formerly owned or operated.

Exhibit No. 7

SECTION V - CERTIFICATIONS

Part I - Transferor/Assignor

All the statements made in the application and attached exhibits are considered material representations, and all the Exhibits are a material part hereof and are incorporated herein as if set out in full in the application.

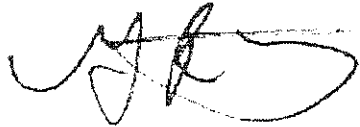
I CERTIFY that the statements in this application are true, complete and correct to the best of my knowledge and belief and are made in good faith.	Signature 
WILLFUL FALSE STATEMENTS MADE ON THIS FORM ARE PUNISHABLE BY FINE AND/OR IMPRISONMENT. U.S. CODE, TITLE 18, SECTION 1001.	Date April 9, 2014
	Print full name Gary R. Matz
Check appropriate classification: <input type="checkbox"/> Individual <input type="checkbox"/> General Partner <input checked="" type="checkbox"/> Corporate Officer <input type="checkbox"/> Other. Explain: (Indicate Title) Senior Vice President of Government Relations	

Part II - Transferee/Assignee

All the statements made in the application and attached Exhibits are considered material representations, and all the Exhibits are a material part hereof and are incorporated herein as if set out in full in the application.

The transferee/assignee certifies that he/she:

- (a) Has a current copy of the FCC's Rules governing cable television systems.
- (b) Has a current copy of the franchise that is the subject of this application, and of any applicable state laws or local ordinances and related regulations.
- (c) Will use its best efforts to comply with the terms of the franchise and applicable state laws or local ordinances and related regulations, and to effect changes, as promptly as practicable, in the operation system, if any changes are necessary to cure any violations thereof or defaults thereunder presently in effect or ongoing.

I CERTIFY that the statements in this application are true, complete and correct to the best of my knowledge and belief and are made in good faith.	Signature 
WILLFUL FALSE STATEMENTS MADE ON THIS FORM ARE PUNISHABLE BY FINE AND/OR IMPRISONMENT. U.S. CODE, TITLE 18, SECTION 1001.	Date April 9, 2014
	Print full name Lynn R. Charytan
Check appropriate classification: <input type="checkbox"/> Individual <input type="checkbox"/> General Partner <input checked="" type="checkbox"/> Corporate Officer <input type="checkbox"/> Other. Explain: (Indicate Title) Senior Vice President, Legal Regulatory Affairs and Senior Deputy Counsel	

Exhibit 1

Time Warner Cable Inc., Comcast Corporation and Tango Acquisition Sub, Inc., entered into an Agreement and Plan of Merger dated as of February 12, 2014. Briefly stated, pursuant to the Agreement and Plan of Merger, Time Warner Cable Inc. will merge with and into Tango Acquisition Sub, Inc., a wholly-owned subsidiary of Comcast Corporation, with Time Warner Cable Inc. as the surviving company. Time Warner Cable Inc. will thereby become a wholly-owned subsidiary of Comcast Corporation. A copy of the Agreement and Plan of Merger as filed with the Securities and Exchange Commission (Form 8-K) is available at www.comcastcorporation.com/together under "Official Filings." Certain information, including Exhibits and Schedules to the Agreement and Plan of Merger, have been omitted, as the information is not necessary in order to understand the terms of the Agreement and Plan of Merger or contain confidential trade, business, pricing or marketing information, or other information not otherwise publicly available. In addition, Comcast Corporation filed a Securities and Exchange Commission Form S-4 Registration Statement on March 20, 2014. A copy is available at www.comcastcorporation.com/together under "Official Filings." Hard copies of either document will be provided upon request.

Exhibit 2

Comcast Corporation will be the indirect parent company of the legal entity holding the franchise for the cable system that is the subject of this Form 394. Comcast Corporation and the legal entity holding the franchise for the cable system that is the subject of this Form 394 have no current plans to change the terms and conditions of service or operations of the system. The cable system will be operated pursuant to the terms of the franchise agreement and applicable law after the consummation of the proposed transaction. Comcast Corporation and the legal entity holding the franchise for the cable system that is the subject of this Form 394 reserve the right to make service and operational changes in accordance with the terms of the franchise agreement and applicable law.

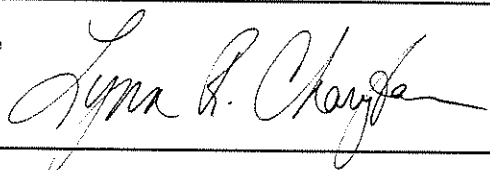
Exhibit 3

Comcast Corporation is a publicly traded Pennsylvania corporation. Comcast Corporation holds a 100% interest in Tango Acquisition Sub, Inc. Time Warner Cable Inc., which is currently the ultimate parent company of the entity that holds the franchise that is the subject of this transaction, will merge with and into Tango Acquisition Sub, Inc., with Time Warner Cable Inc. as the surviving company.

The following persons held a 5% or greater voting interest in Comcast Corporation's Common Stock as of the close of business on March 21, 2014:

<u>Title of Voting Class</u>	<u>Name of Beneficial Owner</u>	<u>Amount Beneficially Owned</u>	<u>% of Class</u>
Class B Voting Stock	Brian L Roberts One Comcast Center Philadelphia, PA 19103	9,444,375	100%*
Class A Common Stock	Brian L Roberts One Comcast Center Philadelphia, PA 19103	5,454,773	Less than 1%

Information Required under Section 2 of FCC Form 394 with Respect to 5% Voting Owners

a) Name and Address	Comcast Corporation One Comcast Center Philadelphia, PA 19103	Brian L. Roberts One Comcast Center Philadelphia, PA 19103
b) Citizenship	N/A	USA
c) Relationship to the Transferee/Assignee	N/A	Chairman
d) Number of Shares	N/A	9,444,375 Class B Common* 5,454,773 Class A Common
e) Number of Votes	N/A	142,387,291
f) Percentage of Votes	N/A	33 1/3%

* Includes 9,039,663 shares of Class B common stock owned by a limited liability company of which Mr. Brian L. Roberts is the managing member and 404,712 shares of Class B common stock owned by certain family trusts of which Mr. Roberts and/or his descendants are the beneficiaries. The shares of Class B common stock beneficially owned by Mr. Brian L. Roberts represent 33 1/3% of the combined voting power of the two classes of our voting common stock, which percentage is generally non-dilutable pursuant to the terms of Comcast's Articles of Incorporation. Under Comcast's Articles of Incorporation, each share of Class B common stock is convertible, at the shareholder's option, into one share of Class A common stock or Class A special common stock. Vote total is calculated based on Class B shares having 15 votes per share and Class A

shares having 0.1323 votes per share as calculated on March 21, 2014, the record date for the Comcast Corporation Proxy Statement.

The officers and directors of Comcast Corporation are as follows.

Officer Name	Title
Brian L. Roberts	Chairman of the Board of Directors
	President
	Chief Executive Officer
Michael J. Angelakis	Vice Chairman
	Chief Financial Officer
David L. Cohen	Executive Vice President
	Chief Diversity Officer
	Assistant Secretary
Neil Smit	Executive Vice President
Stephen B. Burke	Executive Vice President
Alexander D. Evans	Executive Vice President - Global Corporate Development and Strategy
Amy L. Banse	Senior Vice President
Arthur R. Block	Senior Vice President
	General Counsel
	Secretary
David A. Scott	Senior Vice President
Lawrence J. Salva	Senior Vice President
	Chief Accounting Officer
	Controller
William E. Dordelman	Senior Vice President
	Treasurer
A. Melissa Maxfield	Senior Vice President - Congressional and Federal Government Affairs
Jennifer Khoury Newcomb	Senior Vice President - Corporate and Digital Communications
D'Arcy F. Rudnay	Senior Vice President - Corporate Communications
	Chief Communications Officer
Robert S. Pick	Senior Vice President - Corporate Development

Officer Name	Title
Cynthia K. Hook	Senior Vice President - Internal Audit
	General Auditor
Jason S. Armstrong	Senior Vice President - Investor Relations
Lynn R. Charytan	Senior Vice President - Legal Regulatory Affairs
Kathryn A. Zachem	Senior Vice President - Regulatory and State Legislative Affairs
Kristine A. Dankenbrink	Senior Vice President - Taxation
Gerard J. Lewis, Jr.	Chief Privacy Officer
Gary E. Rostick	Vice President
James P. McCue	Vice President
	Assistant Treasurer
Jennifer Heller	Vice President
	Chief Compliance Officer
Jennifer L. Daley	Vice President
	Assistant Treasurer
Justin B. Smith	Vice President
	Chief Joint Venture Compliance Officer
Marc A. Rockford	Vice President
	Senior Deputy General Counsel
Karen Dougherty Buchholz	Senior Vice President - Administration
Charisse R. Lillie	Vice President - Community Investment
Gregg M. Goldstein	Vice President - Corporate Development
Joseph P. McGinley	Vice President - Corporate Development
Mark Noble	Vice President - Corporate Development
Keith T. Cheatham	Vice President - Corporate Real Estate and Insurance
Bret Perkins	Vice President - External and Government Affairs
Kevin P. O'Connor	Vice President - Federal Tax
Joseph F. DiTrollo	Vice President - Financial Operations
Leonard J. Gatti	Vice President - Financial Reporting
Rebecca Arbogast	Senior Vice President - Global Public Policy
Maria Arias	Vice President - Diversity and Inclusion
Sena Fitzmaurice	Vice President - Government Communications

Officer Name	Title
Beth Arnholt	Vice President - Integrated Talent Management
Rudy Briocche	Vice President and Counsel, Global Public Policy
Lindsey Dickinson	Vice President - Legislative Affairs
Sam Lancaster	Vice President - Legislative Affairs
David Don	Vice President - Regulatory Policy
Jordan Goldstein	Vice President - Regulatory Affairs
James J. Finnegan	Vice President - Strategic Intellectual Property
Thomas J. Donnelly	Vice President - Taxation
Directors	
Presiding Director Kenneth J. Bacon	
Brian L. Roberts	
Dr. Judith Rodin	
Eduardo G. Mestre	
Edward D. Breen	
Gerald L. Hassell	
J. Michael Cook	
Jeffrey A. Honickman	
Johnathan Rodgers	
Joseph J. Collins	
Ralph J. Roberts	
Sheldon M. Bonovitz	

Exhibit 4

Comcast Corporation is a Pennsylvania corporation and, as of the effective time of the closing, will be the indirect parent company of the legal entity holding the franchise (the "Franchisee"). To the extent required by applicable law, the Franchisee is and, after the closing of this transaction will continue to be, duly qualified to transact business in the State or Commonwealth in which this system is operated.

Exhibit 5

Comcast Corporation is the indirect parent company of numerous legal entities holding cable franchises. Comcast and its subsidiaries have been involved in thousands of proceedings with franchise authorities. In a very small number of instances, Comcast or certain of its indirect subsidiaries have had an interest in or connection with an applicant that has been dismissed or denied by a franchising authority. The only final denial issued within the past ten years is listed below.

Henry County, Virginia. In June 2005, two FCC Forms 394 were filed with the franchise authority, with the first requesting the assignment of the franchise from Adelphia Communications Corporation to Time Warner Cable and the second requesting a transfer of control of the franchise from Time Warner Cable to a wholly-owned subsidiary of Comcast. The franchise authority denied consent to the transfer applications in order to exercise an alleged right of first refusal to purchase the cable system. The transaction closed subject to an Agreed Order issued by the United States District Court for the Western District of Virginia. A wholly-owned subsidiary of Comcast has provided cable service to the community and has remitted cable service franchise fees since August 1, 2006.

Exhibit 6

A copy of the Comcast Corporation Annual Report on Form 10-K for the year ending December 31, 2013, as well as other filings made with the Securities and Exchange Commission, is available at www.cmcsa.com under "Financials." A hard copy will be provided upon request.

Exhibit 7

Comcast Corporation is a global media and technology company with two primary businesses, Comcast Cable and NBCUniversal. Comcast Cable is the nation's largest multichannel video, high-speed Internet and phone provider to residential customers under the XFINITY brand and also provides these services to businesses. NBCUniversal operates 30 news, entertainment and sports cable networks, the NBC and Telemundo broadcast networks, television production operations, television station groups, Universal Pictures and Universal Parks and Resorts. For additional information about Comcast Corporation, please see the following pages of this Form 394, pages 1 through 11 of the Comcast Corporation Annual Report on Form 10-K for the year ending December 31, 2013, and www.comcastcorporation.com.

Comcast Overview

Overview Comcast Corporation is a global media and technology company with two primary businesses: Comcast Cable and NBCUniversal. Comcast is also a limited partner with venture capital firm Comcast Ventures and is the majority owner of the sports and entertainment company Comcast-Spectacor.

Comcast Cable Comcast Cable is the nation's largest video, high-speed Internet and phone provider to residential customers under the Xfinity brand as well as to businesses.

- Nation's Largest Video Provider: 21.7 million customers
- Nation's Largest Residential High-Speed Internet Provider: 20.7 million customers
- Nation's Fourth Largest Phone Company: 10.7 Million customers
- Combined Customer Relationships: 53.1 million
- Homes and Businesses Passed: 53.8 million
- Operations: 39 states and Washington, D.C.

(As of 12/31/13)

NBCUniversal NBCUniversal is one of the world's leading media and entertainment companies in the development, production, and marketing of entertainment, news, and information to a global audience. NBCUniversal owns and operates a valuable portfolio of news, entertainment and sports television networks, a premier motion picture company, significant television production operations, a leading television stations group, world-renowned theme parks, and a suite of leading Internet-based businesses. NBCUniversal is owned by Comcast Corporation.

- **Broadcast Networks:** NBC and Telemundo. 10 NBC owned and operated local stations and 15 Telemundo owned local stations.
- **Cable Networks and Digital Media Properties:** USA Network, Syfy, E!, CNBC, MSNBC, Bravo, Golf Channel, Oxygen, NBC Sports Network, Esquire Network, Chiller, CNBC World, Cloo, CNBC World, Mun2, Sprout, Universal HD, and 10 regional sports networks and three regional news networks. Digital media properties include Fandango and iVillage.
- **Filmed Entertainment:** Universal Pictures. Production under both the Universal Pictures and Focus Features names.
- **Theme Parks:** Universal Orlando, which includes Universal Studios Florida, Universal's Islands of Adventure and CityWalk; Universal Studios Hollywood.

Founded 1963

Chairman and CEO Brian L. Roberts

Headquarters Philadelphia, PA

Employees Approximately 136,000 full-time and part-time

Ticker Symbol NASDAQ – CMCSA, CMCSK

Corporate Website <http://comcastcorporation.com>

Corporate Blog <http://corporate.comcast.com/comcast-voices>

XFINITY Products <http://www.xfinity.com>

NBCUniversal <http://www.nbcuniversal.com>



XFINITY TV

Overview

Xfinity TV brings customers more of the content they love, wherever they are, on any device. The X1 platform is an Entertainment Operating System that gives customers an interactive TV experience, providing instant access to all of their entertainment. Leveraging Internet Protocol (IP) technology and Comcast's cloud-enabled servers and network, the X1 platform enables customers to get integrated search, personalized recommendations and apps on TV. As part of cloud technology innovation, Comcast is currently rolling out the X1 DVR with cloud technology and live in-home streaming.

Key Offerings

- View 300+ TV channels from major broadcast, cable and premium networks on TV, plus more than 100 HD channels.
- Access more than 50,000 of the best and latest TV shows and movies across Xfinity On Demand
- Stream 50+ live TV channels and thousands of TV shows and movies from Xfinity On Demand at Xfinity.com/TV and the Xfinity TV Go app.
- Download popular TV shows and movies from Xfinity On Demand to the Xfinity TV Go app.
- Watch practically your entire channel line-up of live TV in any room in the house on any device with live in-home streaming.
- Access DVR recordings anywhere in your home through Xfinity.com/TV or the new Xfinity TV app on mobile devices, and download them to your device to watch anytime, anywhere.
- Enjoy a huge selection of current season TV content, the best new release movies from all the major studios, and one of the broadest selections of independent films across platforms on Xfinity On Demand.
- Access to a deep library of movies and TV shows across screens from Xfinity Streampix.
- Schedule the DVR remotely, search live TV and On Demand listings, change the channel on the TV and select favorites online at Xfinity.com/TV and with the Xfinity TV Remote app.
- Use motion and gesture controls to seamlessly find what to watch on live TV and Xfinity On Demand while viewing TV with the X1 Remote Control app.
- Catch popular Spanish-language TV shows, movies, and kids' and music programming online at Xfinity.com/latinotv.
- Watch Xfinity On Demand on the Xbox 360, and quickly find TV shows and movies with voice-activated commands or the wave of a hand via Kinect.
- Access the Xfinity TV app on 2012 Samsung Smart TVs (planned for 2013 SmartTV models in 2014)

For more information about Xfinity TV, visit www.xfinity.com/TV.



XFINITY Internet

Overview Comcast is the nation's largest Internet provider and delivers the fastest Internet speeds, along with reliable service. As the owner and operator of one of the most-advanced fiber-based networks in the country, our scale enables us to deliver more speed to more homes than any other service provider in the U.S. We've also invested in an advanced broadband technology platform, called DOCSIS 3.0. In the past 13 years, we have increased broadband speeds 12 times and we now offer a variety of speed tiers to best fit every customer's needs — from 3 Mbps to the ultra-fast 505 Mbps. Today we deliver up to 10 Gbps speeds to business customers.

Key Offerings Our service is more than just speed. For no additional cost, Internet customers also receive:

- **In-Home Wi-Fi:** Experience the fastest in-home Wi-Fi with our latest XFINITY Wireless Gateway, which can connect dozens of wireless devices.
- **Security:** Connect safely to the Internet with the most comprehensive online security offering in the industry, the Constant Guard Protection Suite (a \$360 value), which includes the top rated Norton Security Suite.
- **XFINITY WiFi:** Stay connected on the go through hundreds of thousands of Wi-Fi hotspots today and even more in the future.
- **XFINITY Connect:** Communicate with family and friends either online or via the XFINITY Connect App, which enables users to send and receive email, access voicemail or manage contacts and digital calendars.

Comcast is also committed to closing the digital divide. We are spearheading an ambitious and comprehensive broadband adoption program called Internet Essentials. Through February 2014, this \$9.95/month service has connected more than 1.2 Million low-income Americans or 300,000 families to broadband Internet at home. For more information, visit InternetEssentials.com (for English) or InternetBasico.com (for Spanish).

For more information about **XFINITY Internet**, visit <http://www.comcast.com/xfinity>.

*As of Q4 2013



XFINITY Voice

Overview XFINITY Voice gives you reliable home phone service with more ways to connect and save. It's an innovative service that delivers unlimited nationwide calling with the best call clarity plus, enhanced features that can help lower your wireless bill. Find your everywhere voice and stay more connected with XFINITY Voice.

Key Offerings

- Unlimited Nationwide Calling and Texting:** With XFINITY Voice you not only get the best call clarity but also Unlimited nationwide calling and texting on Wi-Fi enabled devices at home and on the go. Simply use the free XFINITY Connect app to call and text as much as you like via Wi-Fi without a wireless plan.
- Readable Voicemail:** See what you can't hear and have your voicemails converted to email messages that you can check from anywhere, on any device.
- Assign a Number:** With the free XFINITY Connect app, your iPod Touch and tablet can call and text like a smartphone, without a wireless plan. Assign a personal phone number to up to five Wi-Fi enabled devices and turn your devices into a phone.
- Advanced Call Forwarding:** Whether you're in the car or at work you can still answer your home phone. Connect up to four Wi-Fi enabled devices to your home phone and your calls will always find you.
- Universal Caller ID:** See who's calling your home phone on your TV, computer, home phone and smartphone.

For more information about XFINITY Voice, visit <http://www.comcast.com/xfinity>.

*As of Q4 2013



Comcast Business

Overview Backed by industry-leading, 24/7 tech-class support, Comcast Business provides advanced communication solutions to help companies meet their business objectives. Comcast Business leverages Comcast's powerful, next generation network, our technical and operational expertise and our local resources to offer a wide range of products and services, an enhanced fiber-based network and experienced customer service, all to help a business's bottom line.

Key Offerings

Data Solutions

Comcast Business Internet offers businesses a feature-rich, reliable and secure Internet solution. Comcast offers its business customers four tiers of Internet service with download speeds starting at 16 Mbps downstream and 3 Mbps upstream and going up to 150 Mbps downstream and 20 Mbps upstream via next-generation DOCSIS 3.0. Customers also get additional features such as Cloud Services by Microsoft, advanced security with Norton Business Suite and Website Hosting services at no extra charge.

Comcast Business Ethernet delivers secure, scalable, high-performance point-to-point and multipoint connectivity over a fully owned, national fiber-based network. Optimized for mid-sized business with multiple locations in a metropolitan area or region, Comcast Business Ethernet provides an entirely new level of reliable, scalable and secure Internet connectivity that is significantly faster than legacy technologies.

Voice Solutions

Comcast Business Voice is a reliable voice alternative with integrated and advanced features for businesses that has been rated best in call clarity*. Customers get unlimited local and long-distance calling, and advanced call management and voicemail options including hunt group, call holding, call transfer, three-way calling, call forwarding, business directory listings, the ability to receive email or text notifications of voicemail, the ability to listen and manage voicemail online, and more.

Comcast Business VoiceEdge is a cloud-based voice and unified communications (UC) solution that delivers a common user experience, high-definition (HD) quality voice service and a full suite of productivity-enhancing features that are fully-managed and delivered over Comcast's advanced network. The service comes in complete, affordable packages that include Polycom HD phones, unlimited nationwide calling, professional installation, training options, and a mobile app for Android and iOS.

Comcast Business Trunks provide connectivity between a customer's Private Branch Exchange (PBX) and Comcast's advanced network. The scalable service allows customers to purchase based on the concurrent calls the business needs.

Video Solutions

Comcast Business TV provides reliable and cost-effective video solutions to satisfy a variety of customers' business needs at office locations such as conference rooms and waiting areas. Packages run from basic TV to upgrades including the Sports Pack, Canales Selecto (Hispanic networks) and Music Choices.

Upware

Upware is a suite of business-grade cloud solutions that can be purchased and managed through one integrated web portal. The Upware marketplace (business.comcast.com/Upware) contains business applications from industry-leading companies in key categories, including Data Backup, Data Security, Collaboration, and eSignature. Major Upware partners include DocuSign, Norton, Carbonite, Box, Microsoft and Cisco.

For more information about **Comcast Business**, visit www.business.comcast.com.



**Call clarity claim based upon January 2012 call clarity analysis by Tektronix*

Updated Q4 2013

XFINITY Home

Overview XFINITY Home is a broadband and cloud-based platform that provides next-generation home security, control and energy management features. This platform allows customers to stay connected to their home and family through the use of an interactive Web portal, mobile devices and the free XFINITY Home app. In addition to 24/7 professional monitoring, XFINITY Home offers an expanding suite of home control and remote energy management services that include lighting controls, digital thermostats, live video monitoring, custom text and email alerts, remote arming and disarming capabilities, water and carbon monoxide sensors.

Key Offerings **XFINITY Home Features**

- Access security and home automation features and settings from virtually anywhere – through a portable touch screen console in the home, on a computer or tablet, and on a smartphone through the XFINITY Home app.
- Control and set timing with smart energy management features, including programming lights to turn on and off at designated times, and schedule or remotely adjust heating and air conditioning settings.
- See what's going on around the home while away with real-time video monitoring on Internet-connected devices.
- Receive real-time text and email alerts when doors and windows open or close.
- Check the weather, voicemail, news and sports, play games and more with the in-home touch screen console.
- Enjoy peace-of-mind with added layers of protection, including wireless and battery backup, in addition to the third-party central station that monitors customers' homes 24 hours a day.
- Arm, monitor and control the home with the following available equipment: Window/Door Sensors, Motion Sensors, Glass Break Sensors, Indoor/Outdoor Cameras, Smoke Detectors, Wireless Keypads, Keychain Remotes, Thermostats, Lighting and Appliance Modules, Water/Flood Sensors and Carbon Monoxide Sensors.

For more information about **XFINITY Home** visit www.xfinity.com/home.

*As of Q4 2013



Joseph W. Sokul
DPW Superintendent

E-mail: jsokul@townofgb.org
www.townofgb.org



Town Hall, 334 Main Street
Great Barrington, MA 01230

Telephone: (413) 528-0867
Fax: (413) 528-2290

TOWN OF GREAT BARRINGTON MASSACHUSETTS

DEPARTMENT OF PUBLIC WORKS

EXECUTIVE SUMMARY

TITLE: Extension of Agreement between CET and the Town of Great Barrington for the Collection of Hazardous Waste Through the Multi-Town Collaborative.

BACKGROUND: Each year the Town signs a letter of intent to continue participation in the Berkshire County Household Hazardous Waste Collection Program. The Town also signs an agreement with the Center for EcoTechnology (CET) to coordinate and administer the program as part of the multi-town HHW collection program. The Town carries a line in the annual budget to pay for the fees for this program.

FISCAL: The estimated fee based on the Town of Great Barrington's population is \$3,735. The proposed FY15 budget for this program is \$6,500 which includes collection fees beyond this program.

RECOMMENDATION: Great Barrington continues to be one of the leaders for this program in the County. It is recommended that the Board of Selectmen approve the continued participation in the program and have the appropriate authority sign the agreement.

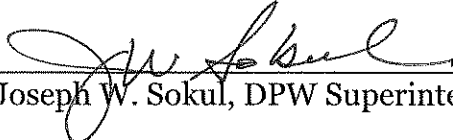
Prepared By:  Date: 06/02/2014
Joseph W. Sokul, DPW Superintendent

Approved By:  Date: 6/17/2014
Jennifer Tabakin, Town Manager

(TOWN LETTERHEAD)

(Date)

Mr. John Majercak
Center for EcoTechnology
112 Elm Street
Pittsfield, MA 01201

**RE: Extension of Agreement between CET and the Town of _____
for the Collection of Hazardous Waste Through the Multi-Town Collaborative.**

Dear Mr. Majercak,

Pursuant to Article F of the above referenced contract, the Town of _____
is hereby exercising its option to extend the term of the contract for an additional year.
Thus, the new expiration date of this Contract will be June 30, 2015.

The parties also agree to submit the first installment of 20% of the annual fee by July 15,
2014. Attachment A stipulating the annual budget and payment is enclosed.

We look forward to the thirteenth year of the South Berkshire Regional Household
Hazardous Waste Collaborative for the collection of household hazardous waste.

For the Town of _____ :

For the Center for EcoTechnology:

(Authorized Signatory)

John Majercak, Executive Director

(Print Name and Title)

(Date)

(Date)

May 27, 2014

MAY 29 2014

Dear Selectmen,

BOARD OF SELECTMEN
GREAT BARRINGTON, MA

The Southern Berkshire Regional Household Hazardous Waste Collection Program is about to enter its thirteenth year of operation. The goal of the program continues to be to increase the opportunities for residents in south county to properly dispose of household hazardous waste while minimizing the cost to each participating municipality. Careful planning and management have allowed us to maintain a high level of service with no additional cost to all fifteen-member communities.

In FY 15, the core program will remain the same. We will hold 7 mini site collections for paint products and oil and 2 comprehensive one-day events. In addition, we will continue accepting fluorescent bulbs. Goodwill has agreed to attend our HHW events to provide collection service for computers and TVs (CRTs) for a small fee. The Steering Committee will continue to promote its educational and outreach efforts by distributing its "How to Reduce, Reuse and Recycle" guide, available for no charge to all member communities.

The Steering Committee recently renewed its service agreement with The Center for EcoTechnology, Inc. (CET) to administer this regional program. A contract extension of this "Service Agreement" is attached for your review and signature.

Included in this packet you will find:

1. A copy of the Contract Extension which should be signed and returned to the Center for EcoTechnology, Inc. (CET) by **June 30, 2014**.
2. A Copy of the Budget for Fiscal-Year 2015. (Attachment A)
3. A Spreadsheet with each town's assessment for Fiscal-Year 2015. (Attachment B) Note that Sandisfield is not participating in FY 2015.
4. The July and October 2014 one-day HHW collections information and the summer 2014 mini-site collection schedule.

The Steering Committee and Center for EcoTechnology, Inc. continue to work very hard to contain costs of providing this valuable service. Faced with increased contract costs for the HHW events, Jamie was able to successfully negotiate favorable pricing for our two FY 2015 events. In addition, CET agreed to administer the program with no cost increase for FY 2015.

The first FY 15 regional one-day HHW event will be taking place in Lee on July 19, 2014. Mark your calendars! The event flyer is attached. A second one-day HHW collection event will take place in October in Great Barrington and more details will follow.

Please look over the material included in this packet and return a signed copy of the contract extension no later than **June 30, 2014** to Center for EcoTechnology, Inc., Attn: Jamie Cahillane at 112 Elm Street, Pittsfield, MA 01201. An initial bill for service will follow immediately. Contact any of the steering committee members with questions. We appreciate your cooperation and enthusiasm. We anticipate continued success as the program begins its thirteenth year.

Sincerely,

Southern Berkshire County Regional HHW Program Steering Committee members

Joe Sokul (Great Barrington)	413-528-0867
Sean VanDeusen (Lenox)	413-637-5525
James Wilusz (Tri Town Health)	413-243-5540
David Steindler (Sheffield)	413-229-2628
Mark Webber (West Stockbridge)	413-232-0300 ext. 319
Arlene Miller (MAC Coordinator)	413-567-5027
and	
Jamie Cahillane for CET	413-445-4556 ext. 14

Attachment A

Proposed Budget FY 2015

Revenue:

Estimated Carry Forward:	\$ 4,000
<u>Income from assessments:</u>	<u>\$ 17,646</u>

TOTAL:	\$ 21,646
--------	-----------

Expenses:

a. Administrative:	\$ 9,750
b. Advertisements:	\$ 3,000
c. Mini site disposal costs	\$ 3,700
<u>d. One-Day event costs</u>	<u>\$ 2,000</u>

TOTAL:	\$18,450
--------	----------

SBHHW FY 2015 Budget

Municipal Share	FY 2015		ATTACHMENT B
Household Hazardous Waste Program	Population	Base Fee, based on Population (@\$.66/per)	Additional Disposal Fees Based on Participation FY 2014
Town	2010 Census		Total Est. Cost of both mini and HHW events (for FY 2015 budget purposes)
Alford	494	\$ 327	\$ 184
Becket	1,779	\$ 1,178	\$ 230
Egremont	1,225	\$ 811	\$ 360
Great Barrington	7,104	\$ 2,401	\$ 1,334
Lee	5,943	\$ 2,736	\$ 1,800
Lenox	5,025	\$ 1,879	\$ 726
Monterey	961	\$ 636	\$ 216
Mount Washington	167	\$ 111	\$ 28
New Marlborough	1,509	\$ 999	\$ 280
Otis	1,612	\$ 1,067	\$ 280
Richmond	1,475	\$ 976	\$ 254
Sheffield	3,257	\$ 2,156	\$ 600
Stockbridge	1,947	\$ 1,289	\$ 996
Tyringham	327	\$ 216	\$ 108
West Stockbridge	1,306	\$ 865	\$ 154
TOTALS	34,131	\$ 17,646	\$ 7,550
*as host communities, Gt. Barrington, Lee and Lenox are assessed at a "host community benefit rate".			
			\$ 25,196

2014 Household Hazardous Waste Collections

Residents of:

Alford	Gt. Barrington	Monterey	Otis	Stockbridge
Becket	Lee	Mt. Washington	Richmond	Tyringham
Egremont	Lenox	New Marlboro	Sheffield	W. Stockbridge

BUSINESSES/SCHOOLS/INSTITUTIONS WELCOME - FEE APPLIES

**Comprehensive
Collection**

Saturday, July 19 9 a.m. - Noon
LEE Waste Water Facility

We're partnering with GoodWill Industries of the Berkshires and Computers, computer Monitors are Free but there is a charge for TV's and other electronics at \$10+

They are accepting clean/dry-bagged clothing and textiles as well!

Propane Tanks: (no other tanks): up to 20 lbs, one free per car, after that - \$10 each.

Or, bring to Lenox Valley WTF in Lenoxdale, no charge

Acceptable Material:

From the workbench: Oil Based (No Latex) Paints, Stains & Varnishes, Wood Preservatives, Paint Strippers/Thinners, Solvent Adhesives, Lighter Fluid
From the garage: Fuels/Gasoline/Kerosene, Antifreeze, Degreasers, Driveway Sealer, Brake Fluid/Carburetor Cleaner, Transmission Fluid, Car Wax, Polishes, Roofing Tar, Pool Chemicals

From the yard: Poisons, Insecticides, Fungicides, Fertilizers, Weed Killers, Moth Balls, Flea Control Products

From the house: Rubber Cement, Airplane Glue, Fiberglass Resins, Photo Chemicals, Chemistry Sets, Floor & Metal Polish, Oven Cleaner, Drain & Toilet Cleaner, Spot Remover, Rug/Upholstery Cleaner, Hobby/Artist Supplies, Mercury Thermometers & Thermostats, Button Batteries, Rechargeable batteries, Compact and Tube Fluorescent lamps, ballasts. Asbestos (double bagged and wetted)

***NOT ACCEPTING:** Latex Paint, Motor Oil, Medical Wastes, Fireworks & Explosives, Ammunition, non-propane cylinders, Smoke Detectors, Radioactive Material, Fire Extinguishers, Empty Aerosol Cans, PCB's, Paint brushes/frags, Asbestos tiles, alkaline batts.

Locations

Lee Waste Water Plant, Rt. 102 about 1/2 mile west of Big Y

Gt. Barrington - Transfer Station, Rt. 7, across from Monument Mountain HS

Pre-Reg mandatory-Register online: <http://www.cetonline.org/events/>

email: Jamie.Cahillane@cetonline. or call(888) 577-8448 ext. 14

2014 Mini-site Collections

Residents of:

Alford	Gt. Barrington	Monterey	Otis	Stockbridge
Becket	Lee	Mt. Washington	Richmond	Tyringham
Egremont	Lenox	New Marlboro	Sheffield	W. Stockbridge

Mini-site Collections

- Saturday, July 12, 9 am - 11 am
Lenox Dept. of Public Works
- Saturday, August 16, 9 - 11:30 am
Great Barrington Recycling Center
- Tuesday, Sept. 9, 4:30 - 6:30 pm
Lenox Dept. of Public Works
- Saturday, Sept. 27, 9 - 11:30 am
Great Barrington Recycling Center

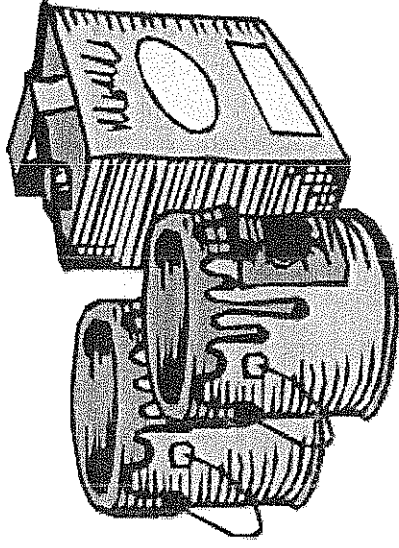

Image courtesy of Centre County Recycling, PA

Acceptable Materials - Used motor oil, Oil based Paints, Spray Paint, Turpentine, Stains, thinners (No Latex Paint)

NOT ACCEPTING: Latex Paint, paint brushes/rags, Medical Wastes, Asbestos, Fireworks & Explosives, Ammunition, Gas Cylinders, Smoke Detectors, Radioactive Material, Fire Extinguishers, Empty Aerosol Cans, PCBs

Locations

Lenox - DPW, 275 Main Street, Route 7A, across from Mass. Highway Dept.
Gt. Barrington - Transfer Station, Rt. 7, across from Monument Mountain HS

(Dates are subject to change) Register online: <http://www.cetonline.org/events/>

Pre-registration mandatory: (888) 577-8448 ext. 14 or Jamie.Cahillane@cetonline.org

DEBORAH PHILLIPS
CHAIR

SEAN A. STANTON
STEPHEN C. BANNON
DANIEL BAILLY
EDWARD ABRAHAMS



Town Hall, 334 Main Street
Great Barrington, MA 01230

Telephone: (413) 528-1619 x2
Fax: (413) 528-2290
website: www.townofgb.org

TOWN OF GREAT BARRINGTON MASSACHUSETTS

SELECTBOARD

W.E.B. Du Bois Family Proclamation 2014

Town of Great Barrington, Massachusetts

Be it hereby known that the Great Barrington Selectboard welcomes the Du Bois family officially into the town's Mahaiwe Cemetery.

Whereas, Great Barrington's famous native son and civil rights leader, William Edward Burghardt Du Bois, laid to rest his son Burghardt (1899), wife Nina (1950), and daughter Yolande (1961) "in soil where my fathers for more than two centuries lived and died."

Therefore, we, the members of the Selectboard of the Town of Great Barrington, Massachusetts, do hereby honor the Du Bois family and desires them everlasting peace.

IN WITNESS THEREOF, We have hereunto set our hands this 23rd day of June, 2014.

Deborah Phillips, Chair

Sean Stanton

Stephen C. Bannon

Daniel Bailly

Edward Abrahams

Presented by: _____
Randy F. Weinstein
The W.E.B. Du Bois Center at Gt. Barrington

Carol Connare
The University of Massachusetts Amherst

FY 2015 Selectboard Appointments:

<u>INTERESTED IN RE-APPOINTMENT</u>	<u>NEW TERM</u>
<u>AGRICULTURAL COMMISSION</u> (3 yr term regular member, 1yr term alternate) 5 members & 1 alternate	
Hilda Banks Shapiro (Alternate member-1 year term) VACANCY (1 Regular member)	YES June 30, 2015
<u>BOARD OF REGISTRARS</u> (3 year term) 4 members including Town Clerk	
VACANCY (1)	
<u>CABLE ADVISORY COMMITTEE</u> (Indefinite Term) 3 Great Barrington Representatives	
VACANCY (1)	INDEFINITE TERM
<u>CULTURAL COUNCIL</u> (3 year term) Minimum of 5 members & maximum of 22 members	
Lee Rogers Jonathon Williams SEVERAL VACANCIES (Will have 6 members now)	NO (6 yr max term served per MGL) NO ----- -----

**INTERESTED
IN
RE-APPOINTMENT**

NEW TERM

CONSERVATION COMMISSION (3 year term)
*Appointed by Town Manager subject to approval of the SB
7 members

David Shanahan YES June 30, 2017

DESIGN ADVISORY COMMITTEE (5 year term)
5 members plus 2 Planning Board members & 2 Historic District Commission members

Olga May Milligan YES June 30, 2019
Stephan Green YES June 30, 2019
VACANCY (1)- Design Professional member

ENERGY COMMITTEE (3 year term)
7 members

Ryan Caruso YES June 30, 2017
Alana Chernila YES June 30, 2017
Michele DiSimone NO -----
VACANCIES (2)

**INTERESTED
IN
RE-APPOINTMENT**

NEW TERM

FENCE VIEWERS (1 year term)
2 members

Harold Shaw
VACANCY (1)

YES

June 30, 2015

HISTORIC DISTRICT COMMISSION (3 year term)
5 members & 2 alternates

Daniel Bailly
Barbara Syer
Marilyn Kalish (Alternate)
VACANCY (1)- Alternate member

YES
YES
NO

June 30, 2017
June 30, 2017

HISTORICAL COMMISSION (3 Year Term)

*Appointed by Town Manager subject to approval of the SB
7 members

Paul Ivory
William Nappo

YES
YES

June 30, 2017
June 30, 2017

**INTERESTED
IN
RE-APPOINTMENT**

NEW TERM

TREE COMMITTEE (3 year term)
11 members & 1 alternate

Lisa Bozzuto
Beth Moser
Maria Ahlin
Steve Adams

YES
YES
YES
NO

June 30, 2017
June 30, 2017
June 30, 2017

VACANCIES (2 Regular members)
VACANCY (1 Alternate member)

ZBA ASSOCIATE MEMBER (2 year term)

***Joint Appointment with ZBA**

2 Associate members

Donald Hagberg ***See attached email**

YES

June 30, 2016